



## Shear Behavior of Exposed Column Base Plate Connections

Yao CUI<sup>1</sup>, Hao Liu<sup>2</sup>, Hao Li<sup>2</sup>

1 Associate Professor, Dept. of Civil Engineering, Dalian University of Technology, Dalian, China.

E-mail: cuiyao@dlut.edu.cn (9 pt)

2 Master student, Dept. of Civil Engineering, Dalian University of Technology, Dalian, China.

### ABSTRACT

To investigate shear transfer in exposed column base plates, nine large scale specimens were subjected to a combination of axial compression, axial tension and lateral shear deformations. The main parameters examined experimentally include the anchor rod quantity, number of anchor rod, arrangement of anchor rod, type of lateral loading, and level of axial compression loading. The test data indicates that all specimens investigated sustain inelastic deformations without strength loss up to column drift ratios as large as 3%, which meets or exceeds typical performance acceptance criteria for connections in seismically detailed special moment frames. The test observations indicated that the current design approach underestimated the shear resistance of exposed column base. The shear transfer mechanisms of exposed column base include the friction between the base plate and the grouted footing and anchor rod bearing. The test observations indicated that the shear resistance contributed by the friction and anchor rod bearing is sufficient for the special moment resisting frame.

**KEYWORDS:** *Exposed column base, anchor rods, shear behavior, hysteretic behavior*

### 1. INTRODUCTION

Column base connections are critical components in steel structures because they transfer axial forces, shear forces and moments to the foundation. Extensive research was conducted on the seismic behavior of exposed column bases, for example, studies on the effect of the base plate thickness on the column base behavior (DeWolf, 1982; Astaneh et al, 1992) and the effect of the base plate size on ductility (Burda and Itani, 1992). In the U.S., publications such as DeWolf (1982), Thambiratnam and Paramasivam (1986), and the AISC Design Guide No. 1 (Fisher and Koliber, 2006) are commonly used as guidelines for the design of exposed column bases. Design provisions have been offered, for instance, AISC Manual of Steel Construction (AISC, 2005), and AISC Seismic Provisions (AISC Seismic, 2005) in the U.S, the ENV1993 Eurocode 3 (ENV, or EuroNorm Vornorm, represents a European pre-standard) (CEN 1992) in Europe, and Recommendation for Design of Connections in Steel Structures (AIJ 2006) in Japan.

Recent studies by Grauvilardel et al. (2005) and Cui et al. (2015) (as shown in Figure 1.1) indicate that in structural systems such as braced frames, a base plate connection may experience extremely large shear-to-moment ratios, such that failure of the connection is dominated by shear. However, experimental investigations of shear transfer in base plates are highly limited, and most current design guidelines are based on adaptations of experimental data from component tests. For example, several studies investigate the frictional behavior between steel and concrete/grout material interfaces. And most studies which investigate anchor rods in base plates focus on concrete failure modes, rather than the failure of anchor rods from axial tension, shear and bending. Thus, there is a lack of experimental research which investigates structural details and modes of failure that may be unique to the entire column base plate component. An investigation of this issue is the primary motivation of this paper.

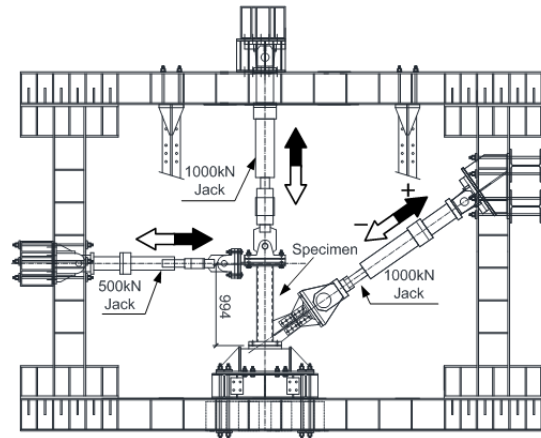

Figure1.1 Test of exposed column base with BRB (Cui et al. (2015))

## 2. EXPERIMENTAL STUDY

### 2.1. Test specimen

Figure 2.1(a) shows the geometry of the specimen. The specimen comprises a steel column and a concrete beam. The column is a square-tube cross section having the width of 200 mm and the thickness of 12 mm. The height from the base plate to the top of the steel column is 560mm to ensure large shear-to-moment ratio. The base plate is 350 mm in width and 40 mm in thickness. The concrete foundation beam was reinforced well to ensure damage will concentrate on the anchor rods rather than concrete foundation beam.

Figure 2.1(b) shows the arrangement of anchor rods of specimens. Four or six machined anchor rods with the nominal diameter of 20 mm were adopted in the test. One specimen with four anchor rods was designed as prototype (4Q). To consider the effect of number of anchor rods, two specimens were designed (6EQ and 6CQ), as shown in Fig. 2.1(b). The arrangement of the anchor rods was changed for both specimens. To consider the effect of axial load, the specimen with four anchor rod was tested with tension axial load. The material properties are shown in Table 2.1.

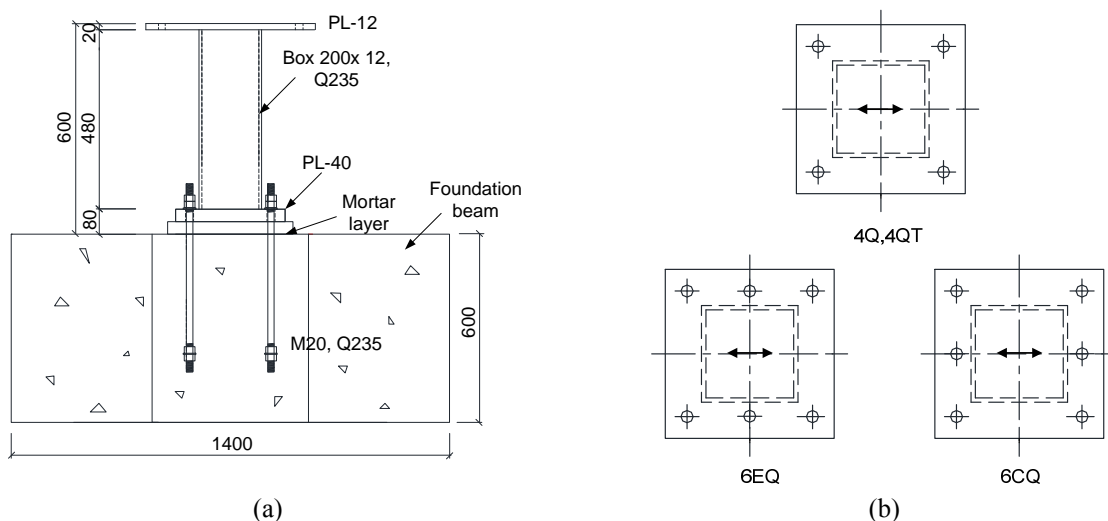

Figure2.1 (a) Geometry of specimen; (b) arrangement of anchor rods (unit:mm)

Table 2.1 Material Properties

		Yield stress, $\sigma_y$ (N/mm <sup>2</sup> )	Tensile stress, $\sigma_u$ (N/mm <sup>2</sup> )
Column	□-200x12, Q235	373	486
Anchor rod	M20, Q235	276	435

	Compressive stress, $\sigma_c$ (N/mm <sup>2</sup> )
Concrete	41
Mortar	50

## 2.2. Test Setup

The test specimen was placed in the loading frame shown in Fig. 2.2. The foundation beam was clamped to the reaction floor. The column top was clamped to two hydraulic jacks, one in the horizontal direction and the other in the vertical direction. The specimens 4Q, 6CQ, 6EQ was subjected to a constant vertical force of 540 kN, corresponding to 0.2 times the yield axial load of the column (12 mm thick). While, the specimen 4QT was subjected to a constant vertical tensile force of 270 kN, corresponding to 0.1 times of the yield axial load of the column. A displacement-controlled cyclic load was applied quasi-statically in the horizontal direction. The displacement was expressed in terms of the drift angle, defined as the horizontal displacement at the loading point relative to the height of the column. Drift angles of 0.0005, 0.005, 0.01, 0.02, 0.03, 0.04, 0.06, 0.08, and 0.1 rad were adopted, and two cycles were performed at each drift angle. The test was terminated when the drift angle reached 0.1 rad or two of the anchor rods fractured, which was regarded as a complete failure.

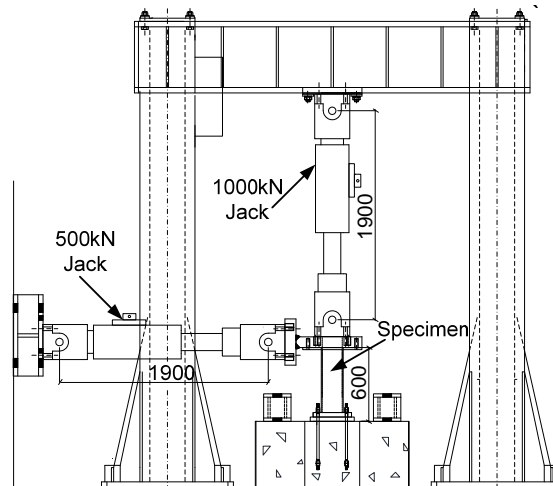
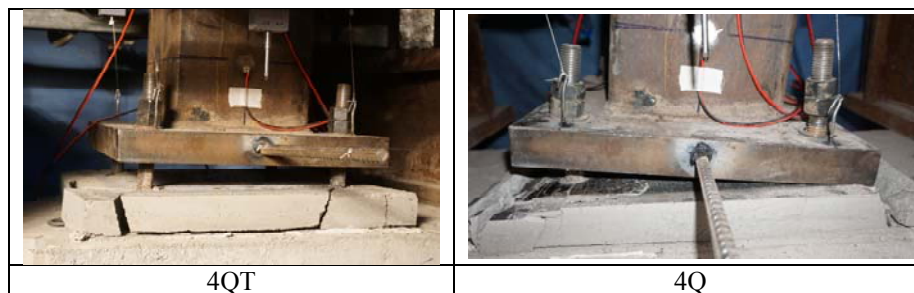

Figure 2.2 Test setup (unit: mm)

## 3. TEST RESULTS

Three specimens under compression axial load were tested till the story drift angle of 0.1 rad was reached. The specimen under tensile axial load (4QT) was stopped at the second loading of story drift angle of 0.04 rad. Figure 3.1 showed the deformation of column base at the ultimate strength. It is noted that in specimen 4QT the base plate was completely separated from the mortar layer, and the anchor rods were elongated significantly in comparison with other specimens. Among the four specimens, only anchor rods of specimen 4QT were fracture. The anchor rods showed good ductility in other three specimens.



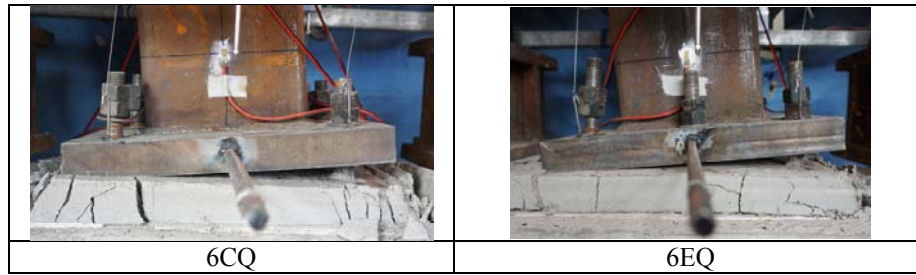

Figure 3.1 Deformation of specimens at the ultimate strength

### 3.1. Level of deformation considered in seismic design

Figure 3.2 shows the relationships between the shear force at the base plate and the story drift of the top of column. The shear strength of the specimen 4QT with axial tensile load reduced significantly compared with the prototype specimen 4Q. The hysteresis behavior of specimen 4QT is completely different from the other three specimens. The specimens with compressive axial load showed slip behavior as expected.

The hysteresis curve of specimen 4Q and 6CQ were symmetrical in positive and negative loading. But the hysteresis curve of specimen 6EQ was unsymmetrical. It is because the two anchor rods were arranged along the column center perpendicular to the loading direction. The contribution of the anchor rods in positive direction and negative direction is therefore different.

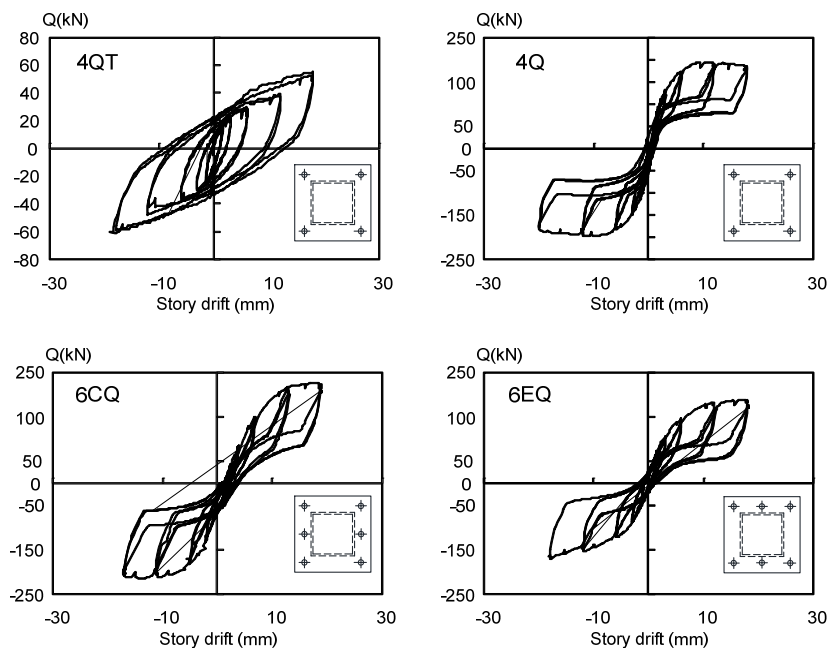

Figure 3.2 Shear force – story drift relationship (Level of deformation considered in seismic design)

### 3.2. Level of deformation beyond that considered in seismic design

Figure 3.3 shows the relationships between the moment at the base plate and the story drift angle till the end of loading. Specimen 4QT failed at story drift angle of 0.04rad. And the moment of specimen 4QT was significant smaller than that of specimen 4Q. The moment was reduced by 70%, when the axial force changed from 540 kN in compression to 270 kN in tension.

Hysteresis curves of the specimens under compressive axial load showed slip behavior. The strength deterioration is not observed. The reason may due to the smaller height of column, in which the  $P-\Delta$  effect would be reduced. Compared with Specimen 4Q and 6CQ, specimen 6EQ showed the self-centering behavior. It is could be contributed by the two anchor rods along the center of column perpendicular to the loading direction.

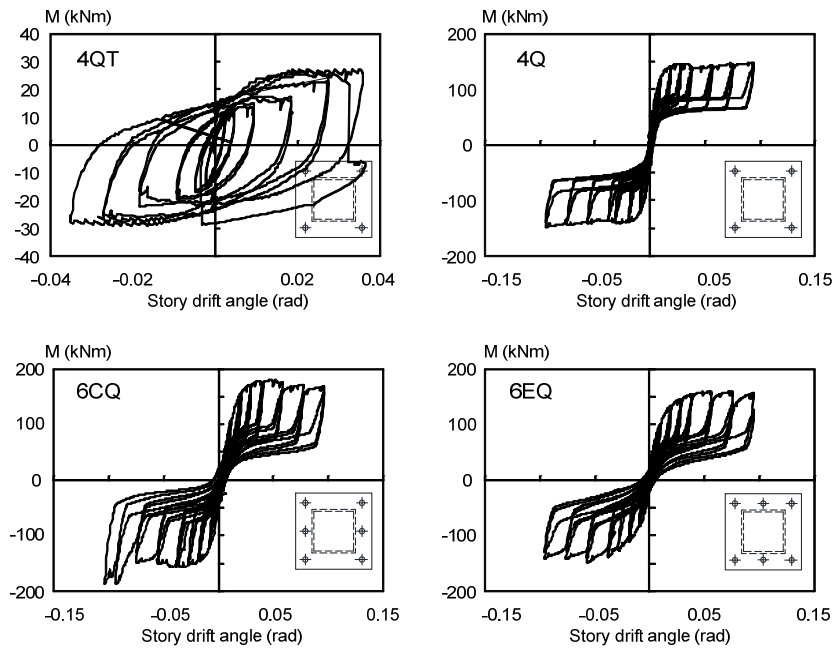

Figure 3.3 Moment – story drift angle relationship

### 3.3. Ultimate strength and hysteretic energy dissipation

Ultimate strength of specimens were listed in Table 3.1 The moment of specimen 4QT was reduced by 70% because of the axial force changed from compressive 540 kN to tensile 270 kN. Although six anchor rods were used, the moments were increased by 17% and 4% for specimen 6CQ and 6EQ. The effect of the arrangement of anchor rods was noted. To ensure larger resistance, the column base should be arranged around the out edge of the base plate.

Table 3.1 Test results

Specimen	Moment (kNm)			Shear Force (kN)		
	Test	Calculation	Cal./Test	Test	Calculation	Cal./Test
4QT	28.1	36.2	1.29	65.2	65.3	1.00
4Q	148.0	154.8	1.05	195.7	350.2	1.79
6CQ	182.9	188.2	1.03	219.5	417.7	1.90
6EQ	154.3	154.8	1.00	189.3	350.2	1.85

Cumulative energy dissipations of each loading cycle for each specimen were illustrated in Figure 3.4. Specimen 4QT showed extremely low energy dissipation capacity. The energy dissipation of specimen 4Q, 6CQ, and 6EQ were quite similar. Specimen 4Q showed larger energy dissipation. It is mainly because that the yield of anchor rods were significant in compared with the anchor rods of the other two specimens.

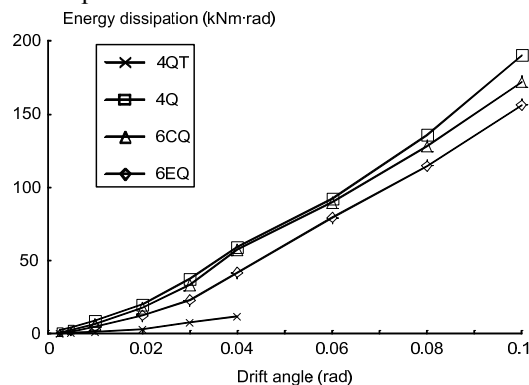

Figure 3.4 Cumulative energy dissipation of each loading cycle

#### 4. ESTIMATION OF ULTIMATE STRENGTH

The calculation method of AIJ (2006) was adopted to evaluate the moment and shear strength of exposed column base in this research. The maximum moment of the specimen is calculated using Eq. 4.1

$$M_u = T_u d_t + \frac{(N + T_u)L}{2} \left(1 - \frac{N + T_u}{N_u}\right) \quad (4.1)$$

Where  $N$  is the axial force;  $N_u$  is the maximum compressive strength of the concrete under the base plate;  $T_u$  is the maximum tensile strength of the anchor bolts acting in the tension region;  $d_t$  is the distance from the column center to the anchor rods in tension;  $L$  is the width of base plate.

The maximum shear resistance is calculated using Eq. 4.2, which is the maximum value of friction resistance (Eq. 4.2a) and shear bearing of anchor rods (Eq. 4.2b).

$$V_u = \max\{V_{fu}, V_{su}\} \quad (4.2)$$

$$V_{fu} = 0.4(N + T_u) \quad (4.2a)$$

$$V_{su} = n_t A_b f_u / \sqrt{3} \quad (4.2b)$$

The comparison between test and calculated results are shown in Table 3.1. The evaluation of moment strength agreed well with the test results with 3~5% difference for the three specimen under compressive axial load. And the evaluation of shear strength agreed well with the test results with minimal error for specimen 4QT. And the difference of evaluated and test shear strength and of the other three specimens were around 70~90%. Such results suggested that specimen 4QT were shear failure and the other three specimens were controlled by moment resisting mechanism.

As shown in Fig. 4.1, the force transfer mechanisms are quite different when the axial load conditions are different. When the tensile axial load was applied, the base plate and mortar layer could be separated. Therefore, the contribution of friction force was zero, anchor rods bearing will contribute to the shear transfer. However, the stress condition of anchor rod would be critical. Anchor rods would resist tension, shear, and moment. The anchor rod capacity would be significantly reduced under such critical stress condition. And slip between base plate and mortar layer was significant large, which was observed in this test and previous braced exposed column base test (Cui et al., 2015).

Under certain situation, the base plate connection will develop additional resistance from friction that would develop from clamping action which arises when the base plate displaces laterally leading to increased tension in the anchor rods. To ensure the column base seismic behavior, the uplift of base plate is suggested to avoid.

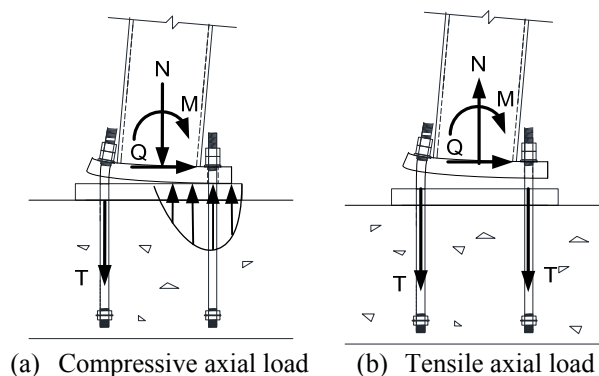

Figure 4.1 Schematic illustration of force transfer

## 5. CONCLUSIONS

A series of quasi-static cyclic loading tests of steel column bases were conducted to investigate shear behavior of column bases. Major test variables were the axial force level, the number of anchor rods, and the arrangement of anchor rods. Major observations obtained from this study are as follows.

1. The maximum strength and dissipated energy were significantly reduced when the axial force changed from compression to tension.
2. The maximum strength was increased when the number of anchor rods increased. But the energy dissipation were not increased as the number of anchor rods increased, since the anchor rods were not yielded much.
3. The strength was reduced significantly when axial force was in tension. It is mainly because the base plate was separated from mortar layer. It is suggested to avoid the uplift of base plate in the design practice.

## AKNOWLEDGEMENT

The writers gratefully acknowledge the financial support provided by the National Science Fund of China (51208076) and the Fundamental Research Funds for the Central Universities (DUT14LK04)

## REFERENCES

4. Astaneh, A., Bergsma, G., and Shen J. H. (1992). Behavior and design of base plates for gravity, wind and seismic loads. *Proceedings of the National Steel Construction Conference*, Las Vegas, Nevada, AISC, Chicago, Illinois.
5. DeWolf, J.T. (1982). Column base plates. *Structural Engineering Practice*, **1:1**, 39-51.
6. Burda, J. J. and Itani, A. M. (1999). Studies of seismic behavior of steel base plates. Report No. CCEER 99-7, Center for Civil Engineering Earthquake Research. Dept. of Civil Engineering, Univ. of Nevada, Reno, Nevada.
7. Thambiratnam, D. P. and Paramasivam, P. (1986). Base plate under axial loads and moments. *J. Struct. Eng.*, **112:5**, 1166-1181.
8. Fisher, J. M. and Kloiber, L. A. (2006). Base plate and anchor rod design (Second edition). Steel Design Guide Series No. 1, AISC, Chicago.
9. American Institute of Steel Construction (AISC). (2005). Steel construction manual, Chicago.
10. American Institute of Steel Construction (AISC). (2005). Seismic provisions for structural steel buildings, Chicago.
11. European Committee for Standardization (CEN). (1992). ENV 1993 Eurocode 3; Design of steel structures, Brussels, Belgium.
12. Architectural Institute of Japan (AIJ). (2006). Recommendations for design of connections in steel structures, Tokyo (in Japanese).
13. Yao C., Shoichi K., Satoshi Y. (2015). Seismic Behavior of Braced Frame Column Base Connections. *Behavior of Steel Structures in Seismic Areas (STESSA2015)*. Shanghai, China.