

Controlling Buildings: A New Frontier in Feedback¹

B.F. Spencer, Jr.² and Michael K. Sain³

The protection of civil structures, including their material contents and human occupants, is without doubt a world-wide priority of the most serious current importance. Such protection may range from reliable operation and comfort, on the one hand, to survivability on the other. Examples of such structures leap to one's mind, and include buildings, offshore rigs, towers, roads, bridges, and pipelines. In like manner, events which cause the need for such protective measures are earthquakes, winds, waves, traffic, lightning, and—today, regrettably—deliberate acts. Indications are that control methods will be able to make a genuine contribution to this problem area, which is of great economic and social importance. In this paper, we review the rapid recent developments which have been occurring in the area of controlled civil structures, including full-scale implementations, actuator types and characteristics, and trends toward the incorporation of more modern algorithms and technologies.

Introduction

One of the exciting new application areas for feedback system design has to do with the protection of civil engineering structures from dynamic loadings such as strong earthquakes, high wind, extreme waves, heavy traffic and highway loading. Buildings and other physical structures, including highway infrastructures, have traditionally relied on their strength and ability to dissipate energy to survive under severe dynamic loading. In recent years, world-wide attention has been directed toward the use of control and automation to mitigate the effects of these dynamic loads on these structures [1–3]. In fact, several buildings in Japan, including a 70-story hotel and a 52-story office complex, are currently employing active control strategies for motion control. Active systems are also used temporarily in

construction of bridges or large span structures (e.g., lifelines, roofs) where no other means can provide adequate protection.

Figure 1 provides a schematic diagram of the structural control problem. The basic task is to determine a control strategy that uses the measured structural responses to calculate an appropriate control signal to send to the actuator that will enhance structural safety and serviceability. To better understand the problem, consider control of the tall building depicted in Fig. 2 using an active mass damper (AMD) system. For this control system, a small auxiliary mass, which is usually less than 1% of the total mass of the structure, is installed on one of the upper floors of the building, and an actuator is connected between the auxiliary mass and the structure. Responses and loads at key locations on the building are measured and sent to the control computer. The computer processes the responses according to the control algorithm and sends an appropriate signal to the AMD actuator. The actuator then reacts against the auxiliary mass, applying inertial control forces to the structure to reduce the structural responses in the desired manner. A wealth of structural control studies have been conducted since Yao [4] first introduced the concept of active control of civil engineering structures. These include, for example, H_2/H_∞ control [5–8], sliding mode control [9–12], saturation control [13,14], reliability-based control [15–21], fuzzy control [22–26], neural control [27,28], modeling and identification [29–32], nonlinear control [33–37], implementation issues [38–43] and benchmark studies [44,45].

The first full-scale application of active control to a building was accomplished by the Kajima Corporation in 1989 [46,47]. The Kyobashi Seiwa building shown in Fig. 3 is an 11-story (33.1 m) building in Tokyo, Japan, having a total floor area of 423 m². A control system was installed, consisting of two

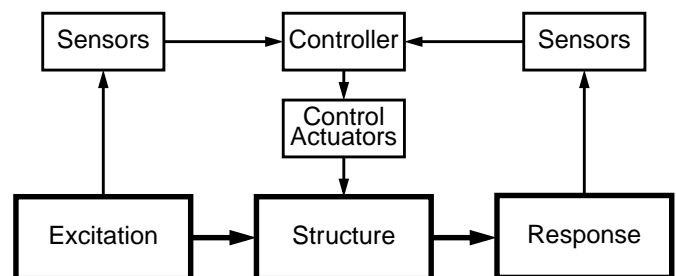

Fig. 1. Schematic Diagram of the Structural Control Problem.

1. The research efforts of the authors from Notre Dame are supported in part by National Science Foundation Grant Nos. CMS 95–00301 and CMS 95–28083. The authors are grateful for the contributions of Profs. T.T. Soong and A.M. Reinhorn of the State University of New York at Buffalo, Prof. Y. Fujino of the University of Tokyo, Japan, Prof. K. Yoshida of Keio University, Japan, and Prof. A. Nishitani of Waseda University, Japan, and Prof. K. Seto of Nihon University, Japan. The authors would also like to thank the reviewers for their careful reading of the manuscript and helpful comments.

2. Department of Civil Engineering and Geological Sciences, University of Notre Dame, Notre Dame, IN 46556, spencer.1@nd.edu

3. Department of Electrical Engineering, University of Notre Dame, Notre Dame, IN 46556, sain@krizevac.ee.nd.edu

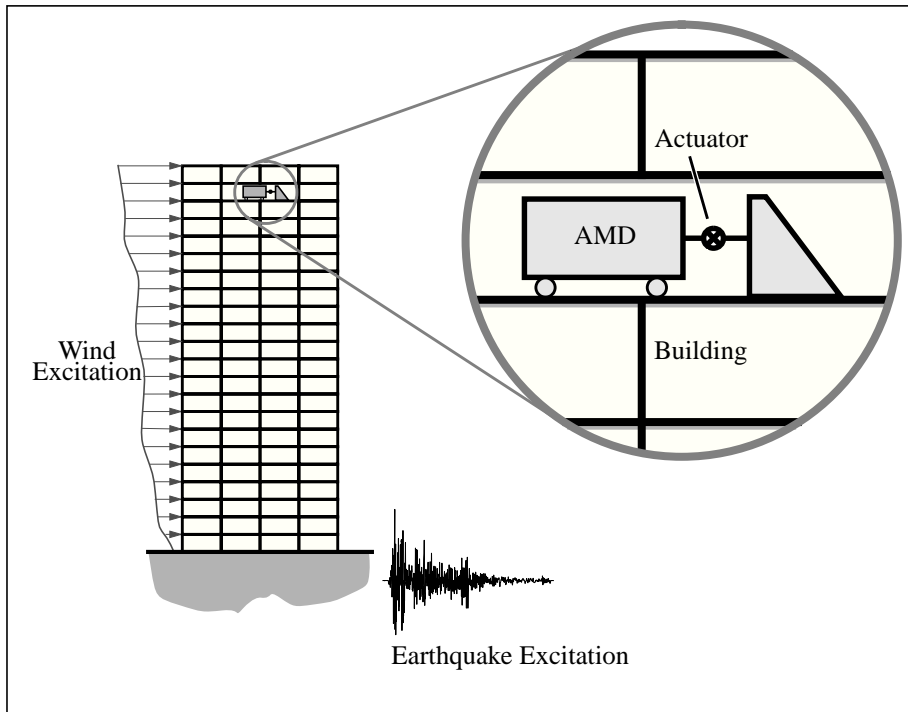

Fig. 2. Concept of the AMD Control System.

AMDs — the primary AMD is used for transverse motion and has a mass of 4 tons, while the secondary AMD has a mass of 1 ton and is employed to reduce torsional motion. The role of the active system is to reduce building vibration under strong winds and moderate earthquake excitations and consequently to increase comfort of occupants of the building.

Although nearly a decade has passed since construction of the Kyobashi Seiwa building, a number of serious challenges remain to be resolved before feedback control technology can gain general acceptance by the engineering and construction professions at large. These challenges include: (i) reduction of capital cost and maintenance, (ii) eliminating reliance on external power, (iii) increasing system reliability and robustness, and (iv) gaining acceptance of nontraditional technology. Hybrid and semi-active control strategies are particularly promising in addressing a number of the challenges to this technology. The next section discusses some of the hybrid control systems, which are more mature. The subsequent section considers recently proposed semi-active control strategies, employing devices that have the possibility to provide the reliability and low power requirements of passive devices, yet maintain the versatility and adaptability of fully active systems. The final section more closely examines a specific semi-active damper, based on the magnetorheological technology, that has substantial promise for civil engineering applications.

Hybrid Control Systems

Hybrid control strategies have been investigated by many researchers to exploit their potential to increase the overall reli-

ability and efficiency of the controlled structure [48]. A hybrid control system is typically defined as one which employs a combination of passive and active devices. Because multiple control devices are operating, hybrid control systems can alleviate some of the restrictions and limitations that exist when each system is acting alone. Thus, higher levels of performance may be achievable. Additionally, the resulting hybrid control system can be more reliable than a fully active system, although it is also often somewhat more complicated. To date, there have been over 20 buildings and 10 bridges (during erection) that have employed feedback control strategies in full-scale implementations (see Tables 1 and 2). The vast majority of these have been hybrid control systems. Research in the area of hybrid control systems has focused primarily on two classifications of systems: i) hybrid mass damper systems, and ii) hybrid base isolation.

Hybrid Mass Damper

The hybrid mass damper (HMD) is the most common control device employed in full-scale civil engineering applications. The HMD is a combination of a tuned mass damper (TMD) and an active control actuator. The ability of this device to reduce structural responses relies mainly on the natural motion of the TMD. The forces from the control actuator are employed to increase the efficiency of the HMD and to increase its robustness to changes in the dynamic characteristics of the structure. The energy and forces required to operate a typical HMD are far less than those associated with a fully active mass damper system of comparable performance.

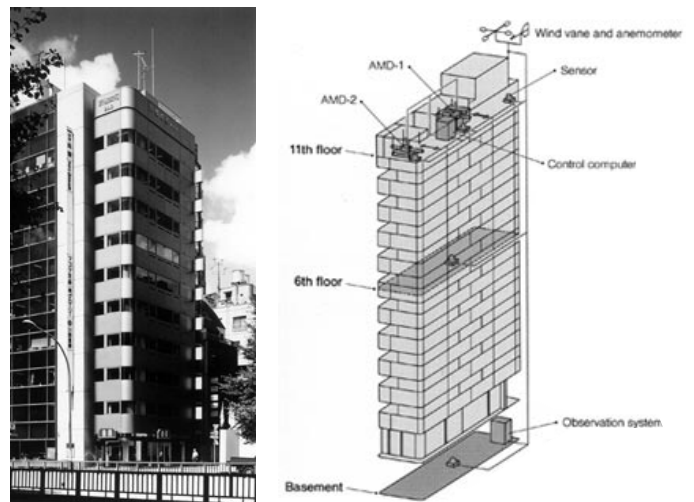

Fig. 3. Kyobashi Seiwa Building with AMD Installation.

Table 1: Summary of Actively Controlled Buildings/Towers.

Full-Scale Structure	Location	Year Completed	Scale of Building	Control System Employed	AMD/HMD		Actuation Mechanism
					No.	Mass (tons)	
Kyobashi Seiwa	Tokyo, Japan	1989	33m, 400 ton, 11 stories	AMD	2	5	hydraulic
Kajima Research Institute KaTRI No. 21 Building	Tokyo, Japan	1990	12m, 400 ton, 3 stories	Active Variable Stiffness System (6 devices)	-	-	hydraulic
Sendagaya INTES	Tokyo, Japan	1992	58m, 3280 ton, 11 stories	AMD	2	72	hydraulic
Applause Tower	Osaka, Japan	1992	161m, 13943 ton, 34 stories	HMD	1	480	hydraulic
Kansai Int. Airport Control Tower	Osaka, Japan	1992	86m, 2570 ton, 7 stories	HMD	2	10	servo motor
Osaka Resort City 2000	Osaka, Japan	1992	200m, 56980 ton, 50 stories	HMD	2	200	servo motor
Yokohama Land Mark Tower	Yokohama, Kanagawa, Japan	1993	296m, 260610 ton, 70 stories	HMD	2	340	servo motor
Long Term Credit Bank	Tokyo, Japan	1993	129m, 40000 ton, 21stories	HMD	1	195	hydraulic
Ando Nishikicho	Tokyo, Japan	1993	54m, 2600 ton, 14 stories	HMD (DUOX)	1	22	servo motor
Hotel Nikko Kanazawa	Kanazawa, Ishikawa, Japan	1994	131m, 27000 ton, 29 stories	HMD	2	100	hydraulic
Hiroshima Riegha Royal Hotel	Hiroshima, Japan	1994	150m, 83000 ton, 35 stories	HMD	1	80	servo motor
Shinjuku Park Tower	Tokyo, Japan	1994	227m, 130000 ton, 52 stories	HMD	3	330	servo motor
MHI Yokohama Bldg.	Yokohama, Kanagawa, Japan	1994	152m, 61800 ton, 34 stories	HMD	1	60	servo motor
Hamamatsu ACT Tower	Hamamatsu, Shizuoka, Japan	1994	212m, 107500 ton, 46 stories	HMD	2	180	servo motor

Table 1: Summary of Actively Controlled Buildings/Towers.

Full-Scale Structure	Location	Year Completed	Scale of Building	Control System Employed	AMD/HMD		Actuation Mechanism
					No.	Mass (tons)	
Riverside Sumida	Tokyo, Japan	1994	134m, 52000 ton, 33 stories	AMD	2	30	servo motor
Hikarigaoka J-City	Tokyo, Japan	1994	110m, 29300 ton, 26 stories	HMD	2	44	servo motor
Miyazaki Phoenix Hotel Ocean 45	Miyazaki, Japan	1994	154m, 83650 ton, 43 stories	HMD	2	240	servo motor
Osaka WTC Bldg.	Osaka, Japan	1994	252m, 80000 ton, 52 stories	HMD	2	100	servo motor
Dowa Kasai Phoenix Tower	Osaka, Japan	1995	145m, 26000 ton, 28 stories	HMD (DUOX)	2	84	servo motor
Rinku Gate Tower North Bldg.	Osaka, Japan	1995	255m, 75000 ton, 56 stories	HMD	2	160	servo motor
Hirobe Miyake Bldg.	Tokyo, Japan	1995	31m, 273 ton, 9 stories	HMD	1	2.1	servo motor
Plaza Ichihara	Chiba, Japan	1995	61m, 5760 ton, 12 stories	HMD	2	14	servo motor
TC Tower	Kao Hsung, Taiwan	1996	85 stories	HMD	2	350	servo motor
Nanjing Tower	Nanjing, China	1997/98	310m	AMD	1	60	hydraulic

Many researchers have made significant contributions toward development of HMDs that are compact, efficient and practically implementable. A number of innovative, long-period devices have been reported. For example, Tanida, et al. [49] developed an arch-shaped HMD that has been employed in a variety of applications, including bridge tower construction, building response reduction and ship roll stabilization. An arch-shaped hybrid mass damper (see Fig. 4) was used during erection of the bridge tower (height = 119m) of the Rainbow suspension bridge in Tokyo to reduce large-amplitude vortex-induced vibration expected to occur at a wind speed of 7m/s [49,50]. The mass ratio for the hybrid damper used for the Rainbow bridge tower was 0.14% of the first modal mass of the structure, whereas a comparable passive TMD would require a 1% mass ratio to achieve a similar level of performance. Figure 5b shows an extension of the arch-shaped HMD, the V-shaped HMD [51], which has the advantage of having an easily adjustable fundamental period. Three of these devices were installed in the Shinjuku Park Tower, the largest building in Japan, in terms of square footage (see Fig. 5a).

Two multi-step pendulum HMDs each having a mass of 170 tons [52] have been developed and installed in the Yokohama Landmark Tower, Figure 6, the tallest building in Japan. The process of constructing the Landmark Tower provides yet another interesting and attractive application of active control, which is associated with the way in which construction cranes were used during its erection. Active control of the position of the crane was carried out by two fans (see Fig. 7). These fans prevented excessive displacement and rotation of the building panels while hoisting and installing them, even under strong winds. Moreover, the overall efficiency of the crane work was significantly improved, and resulted in reduced construction time for the Tower.

The DUOX HMD [46,53], which attains high control efficiency with a small actuator force, has also been proposed and employed in two buildings (see Fig. 8). Devices similar to the DUOX HMD were also studied by Iemura and Izuno [54]. Otsuka, et al. [55] conducted experiments in which a roller-pendulum based HMD was applied to control a tower experiencing

Table 2: Summary of Bridge Towers Employing Active Control During Erection

Name of Bridge	Years Employed	Height, Weight	Frequency Range (Hz)	Moving Mass, Mass Ratio (% ^a)	Control Algorithm	No. of Controlled Modes
Rainbow Bridge Pylon 1	1991 ~ 1992	119m 4800 tonf	0.26-0.95	6 ton x 2 0.6	Feedback control	3
Pylon 2	1991 ~ 1992	117m 4800 tonf	0.26-0.55	2 ton 0.14	DVFB ^b	1
Tsurumi-Tsubasa Bridge ^c	1992 ~ 1993	183m 3560 tonf	0.27-0.99	10 ton x 2 0.16	Optimal regulator DVFB	1
Hakucho Bridge Pylon 1	1992 ~ 1994	127.9m 2400 tonf	0.13-0.68	9 tonf 0.4	Sub-optimal feedback control	1
Pylon 2	1992 ~ 1994	131m 2500 tonf	0.13-0.68	4 ton x 2 0.36	DVFB	1
Akashi Kaikyo Bridge Pylons 1 & 2	1993 ~ 1995	293m 24,650 tonf	-0.127-	28 ton x 2 0.8	Optimal regulator DVFB	1
Meiko-Central Bridge ^c Pylon 1	1994 ~ 1995	190m 6200 tonf	0.18-0.42	8 ton x 2 0.98-1.15	H _∞ Feedback control	1
Pylon 2	1994 ~ 1995	190 6200 tonf	0.16-0.25	0.17-0.38		1
1st Kurushima Bridge Pylon 1	1995 ~ 1997	112m 1600 tonf	0.23-1.67	6 ton x 2 0.15-2.05	Sub-optimal regulator control	3
Pylon 2	1995 ~ 1997	145m 2400 tonf	0.17-1.70	10 ton x 2 0.3-2.6	H _∞ Feedback control	3
2nd Kurushima Bridge Pylon 1	1994 ~ 1997	166m 4407 tonf	0.17-1.06	10 ton x 2 0.41	DVFB/H _∞	2
Pylon 2	1995 ~ 1997	143m 4000 tonf	0.20-1.45	10 ton x 2 0.54-1.01	Fuzzy control	more than 3
3rd Kurushima Bridge Pylon 1	1995 ~ 1996	179m 4500 tonf	0.13-0.76	11 ton x 2 0.3-2.4	Variable gain DVFB	1
Pylon 2	1994 ~ 1996	179m 4600 tonf	0.13-0.76	11 ton x 2 0.3-2.4	H _∞ output feedback control	1
Nakajima Bridge ^c	1995 ~ 1996	71m 580 tonf	0.21-1.87	3.5 ton x 2 1.0-10.6	Fuzzy control	3

a. Percent of first modal mass.

b. Direct Velocity Feedback.

c. Cable-stayed bridge. Others are suspension bridges.

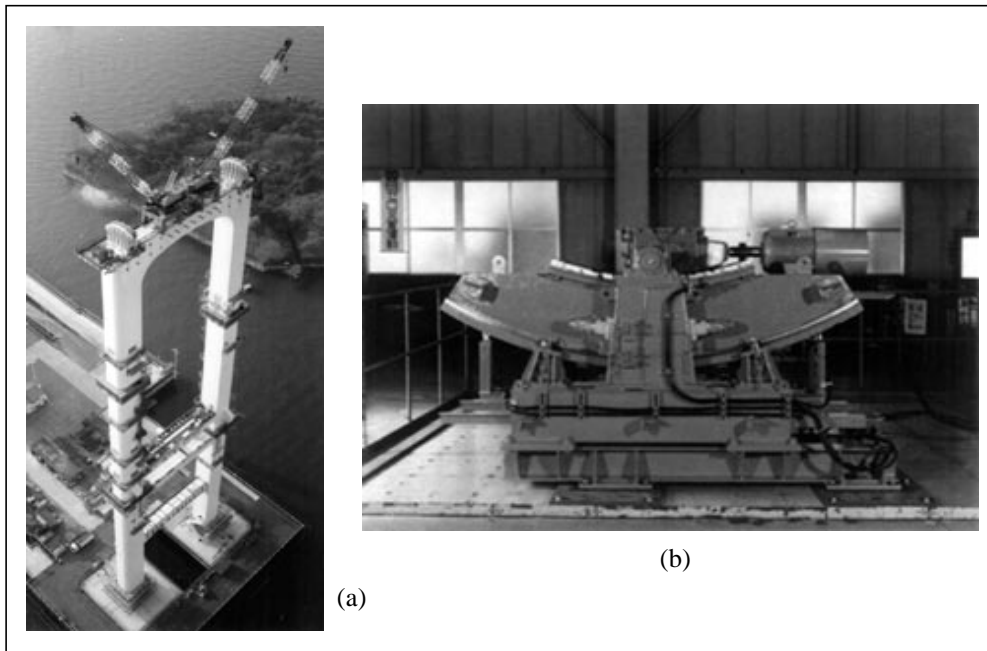

Fig. 4. (a) Rainbow Bridge Tower while under construction; (b) HMD Employed during tower erection.

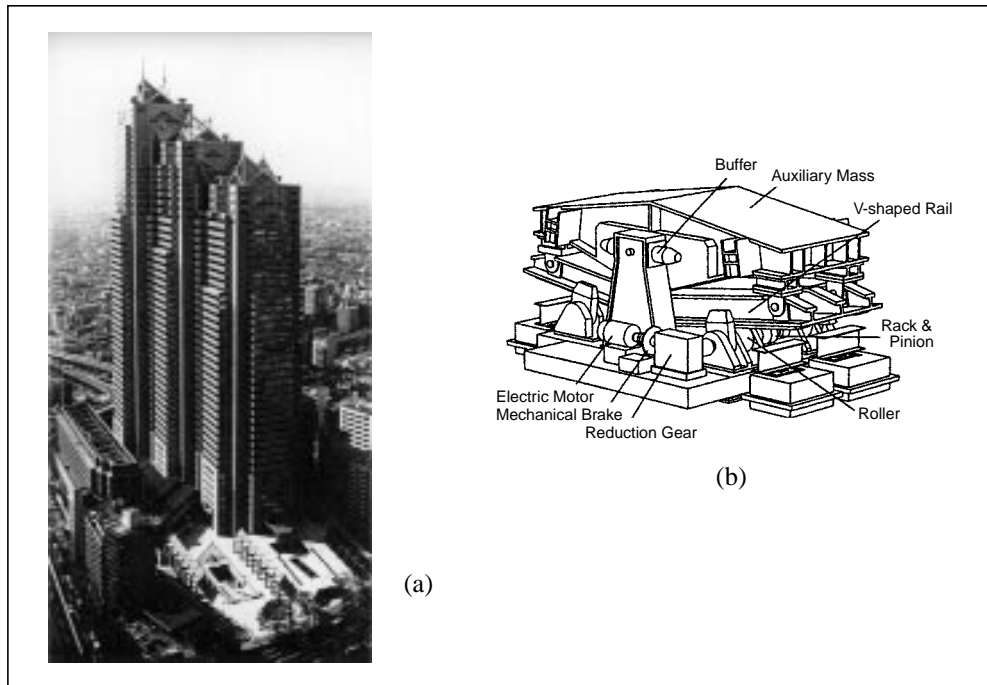

Fig. 5. (a) Shinjuku Park Tower; (b) V-Shaped Hybrid Mass Damper employed in the Shinjuku Park Tower;

seismic excitation. Information regarding similar full-scale structural control implementations employing HMDs have been well documented (e.g., see [47,51,57–69]).

The active/hybrid mass damper is also effective for retrofit applications. Figure 9 depicts the Nanjing Tower, a 340-meter high television transmission and observation tower recently

constructed in Nanjing, China. The tower has two observation decks, the uppermost being at 240 m. During storms, excessive vibration occurs and accelerations at this upper deck can exceed human comfort limit of 0.15 m/sec^2 . Cheng, et al. [56] proposed to use an HMD system, combining a control actuator with a passive tuned liquid damper to control wind-induced vibration of the tower. Because the structure already existed, numerous physical constraints had to be accommodated in the control system design process. Wu and Yang [73] considered continuous sliding mode control of the Nanjing Tower. The design chosen to be implemented in the in the Nanjing Tower to bring the structural responses to within acceptable limits is an innovative active mass damper system reported in Cao, et al. [71] and Riley, et al. [72]. This design, employing a 60-ton ring-shaped mass on sliding friction bearings, was shown adequately reduce the structural response via a nonlinear control policy, while not violating the constraints. This research was conducted as part of the US-People's Republic of China cooperative program through the National Science Foundation.

A number of other interesting ideas employing the mass damper concept have been proposed. Seto [70,74] investigated the possibility of using active or passive forces acting between two adjacent structures to reduce the seismic response of both structures. As viewed from actual construction, many modern buildings might be divided into two or more adjacent substructures with connecting elements. Mita and Feng [75], Mita and Kaneko [76] and Chai and Feng [77] presented studies of mega-sub control systems for

tall buildings. The control system takes advantage of the mega-structure configuration by designing the sub-structures contained in the mega-structure to act as multi-degree of freedom tuned mass dampers. This approach implies that the sub-systems act as vibration absorbers, and hence no additional mass is required as would be the case with a more conventional design.

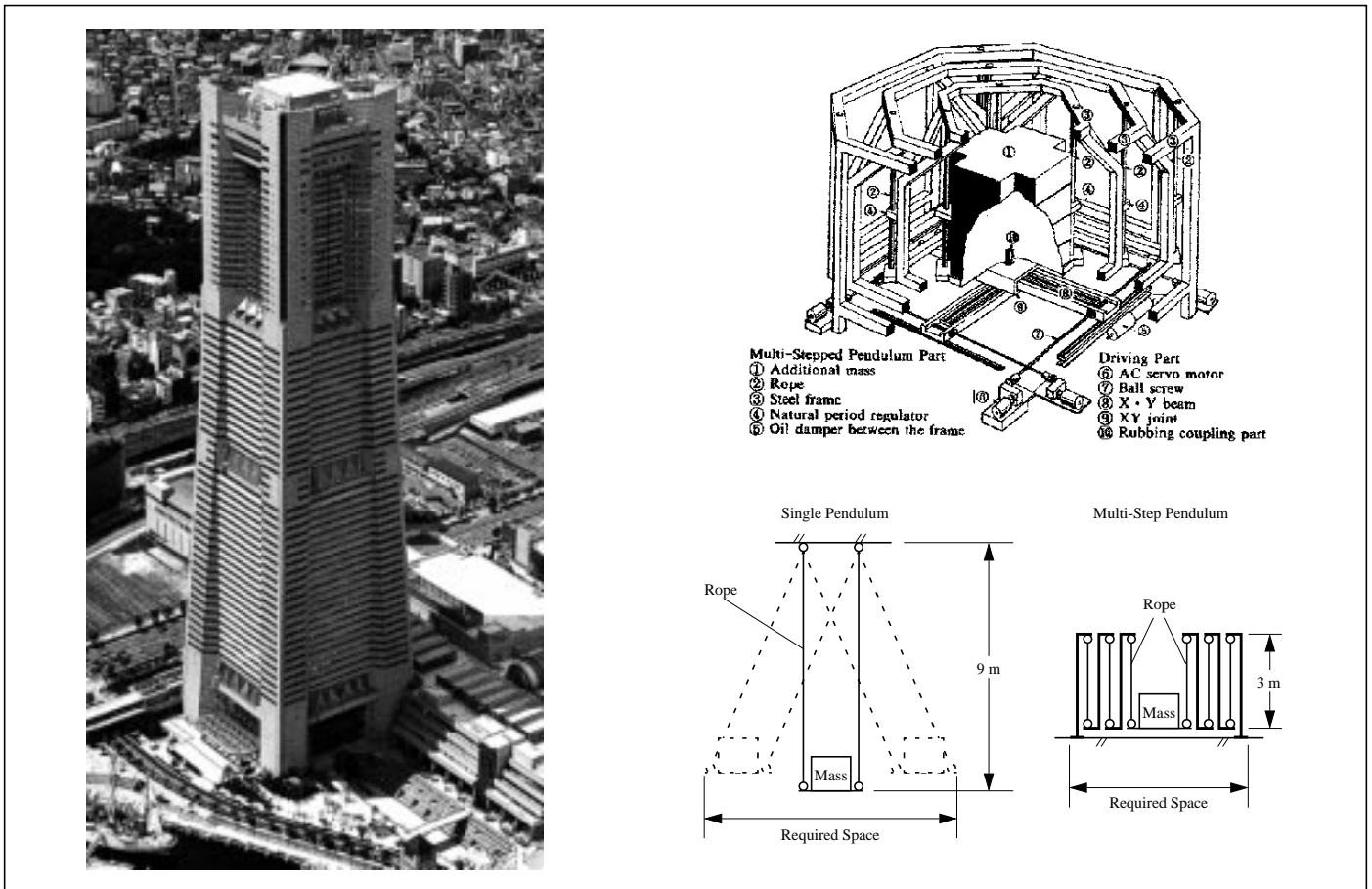

Fig. 6. Multi-Step Pendulum Damper used in the Yokohama Landmark Tower.

Craig, et al. [78] showed that hybrid control schemes, combining a simple active mass damper with the passive damping provided by cladding-structure interaction [79], doubled the reduction in peak response due to passive damping alone.

Researchers have investigated various control methods for HMDs. For example, Shing, et al., [80], Kawatani, et al. [81], Petti, et al. [82], Suhardjo, et al. [5] and Spencer, et al. [6] have considered optimal control methods for HMD controller design. Tamura, et al. [83] proposed a gain scheduling technique in which the control gains vary with the excitation level to account for stroke and control force limitations. Similarly, Niiya, et al. [84] proposed an ad hoc control algorithm for HMDs to account for the limitations on the stroke. Adhikari and Yamaguchi [11] and Nonami, et al. [9] applied sliding mode theory to control structures with HMD systems.

Hybrid Base Isolation

Another class of hybrid control systems which has been investigated by a number of researchers is found in the active base isolation system, consisting of a passive base isolation system combined with a control actuator to supplement the effects of the base isolation system. Base isolation systems have been implemented on civil engineering structures worldwide for a num-

ber of years because of their simplicity, reliability and effectiveness. Excellent review articles of base isolation systems are presented by Kelly [85,86], Buckle and Mayes [87], and Soong and Constantinou [88]. However, base isolation systems are passive systems and are limited in their ability to adapt to changing demands for structural response reduction. With the addition of an active control device to a base isolated structure, a higher level of performance can potentially be achieved without a substantial increase in the cost [89], which is very appealing from a practical viewpoint. Since base isolation by itself can reduce the interstory drift and the absolute acceleration of the structure at the expense of large absolute base displacement, the combination with active control is able to achieve both low interstory drift and, at the same time, limit the maximum base displacement with a single set of control forces. A robust control for uncertain linear base-isolated structures was proposed by Kelly, et al. [90] and more recently by Yoshida, et al. [91], Schmitendorf, et al. [92] and Yang, et al. [93].

Several small-scale experiments have been performed to verify the effectiveness of this class of systems in reducing the structural responses. Reinhorn and Riley [94] performed analytical and experimental studies of a small-scale bridge with a sliding hybrid isolation system in which a control actuator was



Fig. 7. Actively Controlled Crane used during Construction of the Yokohama Landmark Tower

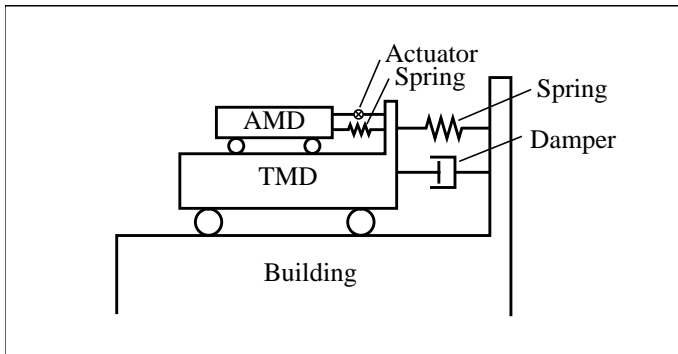

Fig. 8. Concept of the DUOX System.

employed between the sliding surface and the ground to supplement the base isolation system.

Also mentioned in this context is another type of *hybrid* base isolation system which employs a semi-active, friction-controllable fluid bearing in the isolation system. Feng, et al. [95] employed such bearings in a hybrid base isolation system in which the pressure in the fluid could be varied to control the amount of friction at the isolation surface. Yang, et al. [10,96] investigated the use of continuous sliding mode control and variable structure system for a base isolated structure with friction-controllable bearings.

Because base isolation systems exhibit nonlinear behavior, researchers have developed various nonlinear control strategies including fuzzy control [22], neural network based control [27],[28] and robust nonlinear control [97]. In addition, Inaudi,

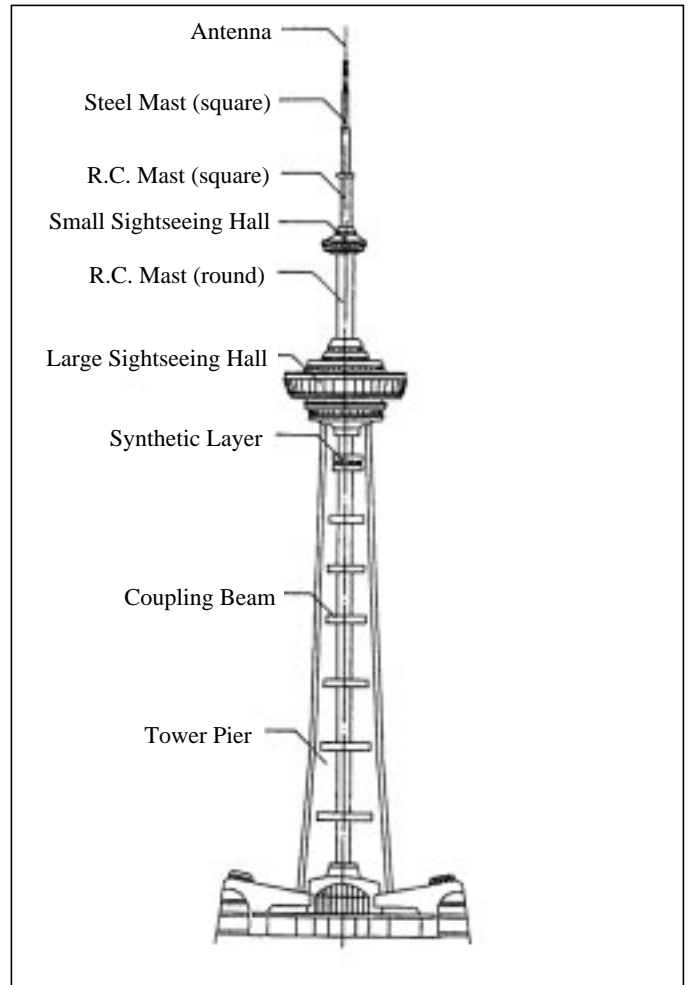

Fig. 9. Nanjing Tower Elevation.

et al. [98] studied the use of frequency domain shaping techniques in designing controllers.

Semi-Active Control Systems

Control strategies based on semi-active devices appear to combine the best features of both passive and active control systems and to offer the greatest likelihood for near-term acceptance of control technology as a viable means of protecting civil engineering structural systems against earthquake and wind loading. The attention received in recent years can be attributed to the fact that semi-active control devices offer the adaptability of active control devices without requiring the associated large power sources. In fact, many can operate on battery power, which is critical during seismic events when the main power source to the structure may fail.

According to presently accepted definitions, a semi-active control device is one which cannot inject mechanical energy into the controlled structural system (i.e., including the structure and the control device), but has properties which can be controlled to optimally reduce the responses of the system. There-

Table 3: .Summary of the Properties of MR and ER Fluids [145, 146].

Property	MR Fluids	ER Fluids
Max. Yield Stress $\tau_{y(\text{field})}$	50–100 kPa	2–5 kPa
Maximum Field	~250 kA/m	~4 kV/mm
Plastic Viscosity, η_p	0.1–1.0 Pa·s	0.1–1.0 Pa·s
Operable Temp. Range	–40 to 150°C	+10 to 90°C
Stability	Unaffected by most impurities	Cannot tolerate impurities
Response Time	milliseconds	milliseconds
Density	3 to 4 g/cm ³	1 to 2 g/cm ³
$\eta_p/\tau_{y(\text{field})}^2$	10^{-10} – 10^{-11} s/Pa	10^{-7} – 10^{-8} s/Pa
Maximum Energy Density	0.1 Joules/cm ³	0.001 Joules/cm ³
Power Supply (typical)	2–25V 1–2 A	2000–5000 V 1–10 mA

fore, in contrast to active control devices, semi-active control devices do not have the potential to destabilize (in the bounded input/bounded output sense) the structural system. Preliminary studies indicate that appropriately implemented semi-active systems perform significantly better than passive devices and have the potential to achieve the majority of the performance of fully active systems, thus allowing for the possibility of effective response reduction during a wide array of dynamic loading conditions [99–101]. Examples of such devices will be discussed in this section, including variable-orifice fluid dampers, variable-stiffness devices, controllable friction devices, controllable tuned liquid dampers, controllable-fluid dampers and controllable impact dampers.

Variable-Orifice Dampers

One means of achieving a variable-damping device is to use a controllable, electromechanical, variable-orifice valve to alter the resistance to flow of a conventional hydraulic fluid damper. A schematic of such a device is given in Fig. 10. The concept of applying this type of variable-damping device to control the motion of bridges experiencing seismic motion was first discussed by Feng and Shinozuka [102], Kawashima and Unjoh [103] and Kawashima, et al. [104]. Subsequently, variable-orifice dampers have been studied by Symans, et al. [105] and Symans and Constantinou [106] at the National Center for

Earthquake Engineering Research in Buffalo, New York.

Sack and Patten [107] conducted experiments in which a hydraulic actuator with a controllable orifice was implemented in a single-lane model bridge to dissipate the energy induced by vehicle traffic (see also [108]). Figure 11 shows a full-scale experiment being conducted by Sack and Patten on a bridge on interstate highway I-35 in Oklahoma to demonstrate this technology. This experiment constitutes the first full-scale implementation of structural control in the United States.

The effectiveness of variable-orifice dampers in controlling seismically excited buildings has been demonstrated through both simulation and small-scale experimental studies [109–117]. Kobori, et al. [118] and Kamagata and Kobori [119] implemented a full-scale variable-orifice damper in an active variable-stiffness system to investigate adaptive control methods for an active variable-stiffness system at the Kobori Research Complex. The results of these analytical and experimental studies indicate that this device is effective in reducing structural responses.

Variable-Friction Dampers

Various semi-active devices have been proposed which utilize forces generated by surface friction to dissipate vibratory energy in a structural system. Akbay and Aktan [120,121] and Kannan, et al. [122] proposed a variable-friction device which consists of a friction shaft which is rigidly connected to the structural bracing. The force at the frictional interface was adjusted by allowing slippage in controlled amounts. A similar device was considered at the University of British Columbia [123–125]. Through analytical studies, the ability of these semi-active devices to reduce the interstory drifts of a seismically excited structure was investigated [125]. In addition, a

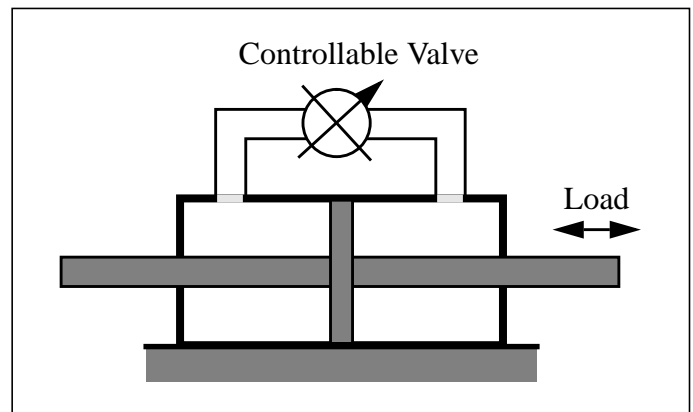

Fig. 10. Schematic of a variable-orifice damper.



Fig. 11. Full-Scale Experiment on Interstate 35 in Oklahoma.

semi-active friction-controllable fluid bearing has been employed in parallel with a seismic isolation system in Feng, et al. [95] and Yang, et al. [96].

Controllable Tuned Liquid Dampers

Another type of semi-active control device utilizes the motion of a sloshing fluid or a column of fluid to reduce the responses of a structure. These liquid dampers are based on the passive tuned sloshing dampers (TSD) and tuned liquid column dampers (TLCD). As in a tuned mass damper (TMD), the TSD uses the liquid in a sloshing tank to add damping to the structural system. Similarly, in a TLCD, the moving mass is a column of liquid which is driven by the vibrations of the structure. Because these passive systems have a fixed design, they are not very effective for a wide variety of loading conditions, and researchers are looking toward semi-active alternatives for these devices to improve their effectiveness in reducing structural responses [126]. Lou, et al. [127] proposed a semi-active device based on the passive TSD, in which the length of the sloshing tank could be altered to change the properties of the device. Haroun, et al. [128] and Abe, et al. [129] presented a semi-active device based on a TLCD with a variable orifice.

Controllable-Fluid Dampers

All of the semi-active control devices discussed until now in this section have employed some electrically controlled valves or mechanisms. Such mechanical components can be problem-

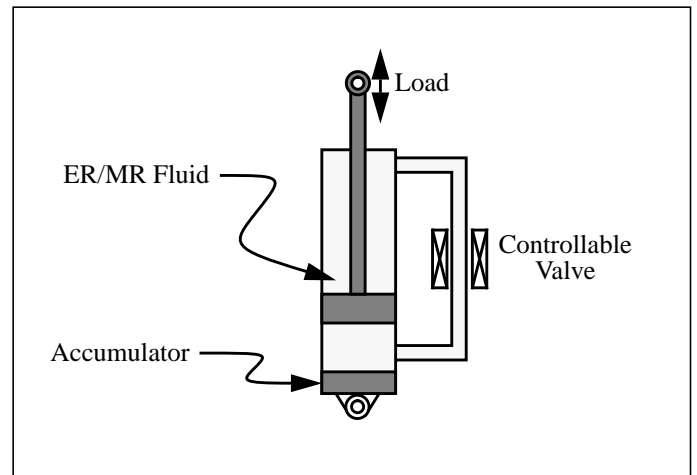

Fig. 12. Schematic controllable fluid damper.

atic in terms of reliability and maintenance. Another class of semi-active devices uses controllable fluids. The advantage of controllable fluid dampers is simplicity; they contain no moving parts other than the piston.

Two fluids that are viable contenders for development of controllable dampers are: (i) electrorheological (ER) fluids and (ii) magnetorheological (MR) fluids. The essential characteristic of these fluids is their ability to reversibly change from a free-flowing, linear viscous fluid to a semi-solid with a controllable yield strength in milliseconds when exposed to an electric (for ER fluids) or magnetic (for MR fluids) field. Although the discovery of both ER and MR fluids dates back to the late 1940's [130–132], research programs have to date concentrated primarily on ER fluids. A number of ER fluid dampers (see Fig. 12) have recently been developed, modeled, and tested for civil engineering applications [133–138].

Recently developed MR fluids appear to be an attractive alternative to ER fluids for use in controllable fluid dampers [139–141] (see also: <http://www.rheonetic.com/mrfluid/> and <http://www.nd.edu/~quake/>). MR fluids have an inherent ability to provide a simple and robust interface between electronic controls and mechanical components. Much of the current interest in MR fluids can be traced directly to the need for reliable, fast-acting valves necessary to enable semi-active vibration control systems [142–144]. MR fluid technology provides the means for enabling such a valve.

A typical magnetorheological fluid consists of 20–40% by volume of relatively pure, soft iron particles, e.g. carbonyl iron, suspended in an appropriate carrier liquid such as mineral oil, synthetic oil, water or a glycol. MR fluids made from iron particles exhibit a yield strength of 50–100 kPa for an applied magnetic field of 150–250 kA/m ($\sim 2\text{--}3$ kOe). MR fluids are not highly sensitive to contaminants or impurities such as are commonly encountered during manufacture and usage. Further, because the magnetic polarization mechanism is not affected by the surface chemistry of surfactants and additives, it is relatively straightforward to stabilize MR fluids against particle-liquid

separation in spite of the large density mismatch. Antiwear and lubricity additives can also be included in the formulation without affecting strength and power requirements [145,146].

As a controllable fluid, the primary advantage of an MR fluid stems from the large, controlled yield stress it is able to achieve. Typically, the maximum yield stress of an MR fluid is an order of magnitude greater than that of the best ER fluid, while their viscosity is comparable. This has a profound impact on ultimate device size and dynamic range, because the minimum amount of active fluid in a controllable fluid device is proportional to the plastic viscosity and inversely proportional to the square of the maximum field induced yield stress [139,141]. This means that for comparable mechanical performance the amount of active fluid needed in an MR fluid device will be about two orders of magnitude smaller than that of an ER device.

From a practical application perspective, an advantage of MR fluids is the ancillary power supply needed to control the fluid. While the total energy and power requirements for comparably performing MR and ER devices are approximately equal [139,141], only MR devices can be powered directly from common, low voltage sources. Further, standard electrical connectors, wires and feedthroughs can be reliably used, even in mechanically aggressive and dirty environments, without fear of dielectric breakdown. This aspect is particularly important in cost sensitive applications.

Another advantage of MR fluids is their relative insensitivity to temperature extremes and contaminants. Carlson and Weiss [140] indicated that the achievable yield stress of an MR fluid is an order of magnitude greater than its ER counterpart and that MR fluids can operate at temperatures from -40 to 150°C with only slight variations in the yield stress. This arises from the fact that the magnetic polarization of the particles, and therefore the yield stress of the MR fluid, is not strongly influenced by temperature variations. Similarly, contaminants (e.g., moisture) have little effect on the fluid's magnetic properties. A summary of the properties of both MR and ER fluids is given in Table 3.

The future of MR devices for civil engineering applications appears to be quite bright. Spencer, et al. [147–149], Carlson and Spencer [150] and Dyke, et al. [99–101] have conducted a number of pilot studies to assess the usefulness of MR dampers for seismic response reduction. Dyke, et al. [99–101] have shown through simulations and laboratory experiments that the MR damper, used in conjunction with recently proposed acceleration feedback control strategies, significantly outperforms comparable passive configurations of the damper for seismic response reduction. More details regarding the application of MR technology to control of civil engineering structures will be given in the next section.

Semi-Active Impact Dampers

Passive impact dampers have been around for many years and have been used very successfully to reduce vibration and noise in turbines and gear cases. Studies of multi-particle dampers under random excitation [151], have shown that significant

vibration reduction can be achieved in lightly damped systems with a relatively small multi-particle impact damper. Single particle dampers of the same total mass give greater vibration reduction in certain frequency bands but may have little or no effect in other frequency bands. To remedy this defect, semi-active control has been applied to impact dampers, such that only favorable impacts are permitted [152–154].

Semi-Active Control of Civil Engineering Structures

Magnetorheological dampers are one of the most promising realizations of semi-active dampers for application to full-scale civil structures. Spencer, et al. [147–149], Dyke, et al. [99–101] and Carlson and Spencer [150] have recently conducted pilot studies to demonstrate the efficacy of MR dampers for semi-active seismic response control. Through simulations and laboratory model experiments, it has been shown that an MR damper, used in conjunction with recently proposed acceleration feedback strategies, significantly outperforms comparable passive damping configurations, while requiring only a fraction of the input power needed by the active controller. Moreover, the technology has been demonstrated to be scalable to devices sufficiently large for implementation in civil engineering structures. This section summarizes these efforts.

Scale-Model Studies

Figure 13 is a diagram of the three-story, model building that was employed in the pilot MR damper studies conducted at the Structural Dynamics and Control / Earthquake Engineering Laboratory at the University of Notre Dame (see <http://www.nd.edu/~quake/>). The test structure used in this experiment is designed to be a scale model of the prototype building discussed in Chung, et al. [38] and is subject to one-dimensional ground motion. A single magnetorheological (MR) damper is

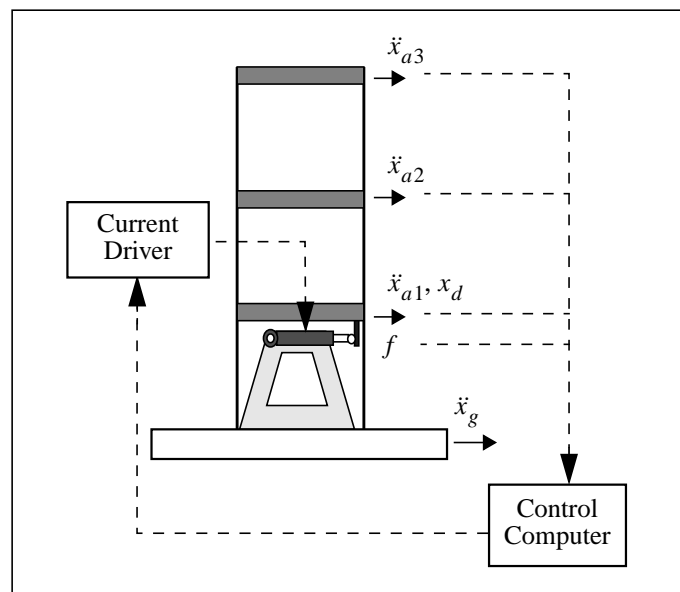

Fig. 13. Diagram of MR Damper Implementation.

installed between the ground and the first floor, as shown in Fig. 13. The MR damper employed here, the Lord SD-1000 linear MR fluid damper, is a small, monotube damper designed for use in a semi-active suspension system in large on- and off-highway vehicle seats. The SD-1000 damper is capable of providing a wide dynamic range of force control for very modest input power levels. The damper is 3.8 cm in diameter, 21.5 cm long in the fully extended position and has a ± 2.5 cm stroke. An input power of 4 watts is required to operate the damper at its nominal maximum design current of 1 amp.

Because of the intrinsically nonlinear nature of all semi-active control devices, development of control strategies that are practically implementable and can fully utilize the capabilities of these unique devices is a challenging task. Various nonlinear control strategies have been developed to take advantage of the particular characteristics of the semi-active devices, including bang-bang control [138], clipped optimal control [99–101,108,112], bi-state control [108,112], fuzzy control methods [155], modulated homogeneous friction [156] and adaptive nonlinear control [119]. Caughey [157] proposed a variable stiffness algorithm that employed a semi-active implementation of the Reid spring [158] as a structural element which could provide large amounts of damping for a very small expenditure of control energy.

To evaluate the effectiveness of the semi-active control system employing the MR damper, acceleration feedback control strategies [99–101] based on H_2 performance measures were implemented on the laboratory structure. The three-story model structure was subjected to a scaled version of the N-S component of the 1940 El Centro earthquake and the measured responses were recorded. Figure 14 shows the uncontrolled (i.e., without the MR damper attached) and semi-actively controlled responses for the tested structure. The effectiveness of the proposed control strategy is clearly seen, with peak third floor displacement being reduced by 74.5% and the peak third floor acceleration being reduced by 47.6%.

The semi-active control systems performed significantly better than two passive configurations that were simultaneously

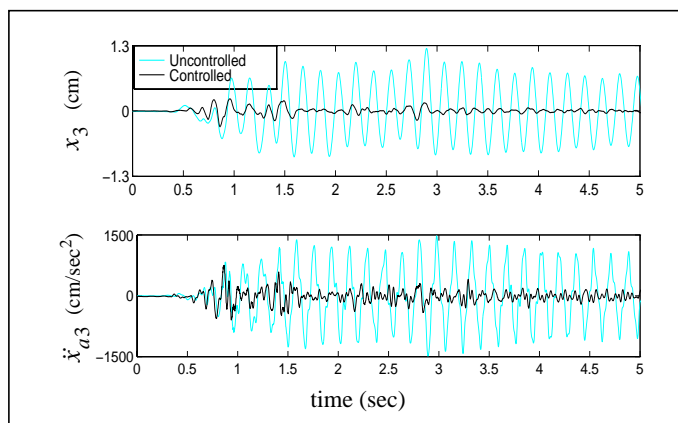

Fig. 14. Controlled and Uncontrolled Structural Responses due to El Centro Earthquake.

considered. A 24.3% reduction in the peak third floor displacement and a 29.1% reduction in the maximum interstory displacement were achieved as compared to the best passive case. Moreover, these results were obtained while also achieving a modest reduction in the maximum acceleration over the comparable passive case. These results demonstrate the significant potential for the use of MR technology in dynamic hazard mitigation.

Full-Scale Seismic MR Damper.

To prove the scalability of MR fluid technology to devices of appropriate size for civil engineering applications, a full-scale, MR fluid damper has been designed and built [149,150]. For the nominal design, a maximum damping force of 200,000 N (20-ton) and a dynamic range equal to ten were chosen. A schematic of the large-scale MR fluid damper is shown in Fig. 15. The damper uses a particularly simple geometry in which the outer cylindrical housing is part of the magnetic circuit. The effective fluid orifice is the entire annular space between the piston outside diameter and the inside of the damper cylinder housing. Movement of the piston causes fluid to flow through this entire annular region. The damper is double-ended, i.e. the piston is supported by a shaft on both ends. This arrangement has the advantage that a rod-volume compensator does not need to be incorporated into the damper, although a small pressurized accumulator is provided to accommodate thermal expansion of the fluid. The damper has an inside diameter of 20.3 cm and a stroke of ± 8 cm. The electromagnetic coil is wound in three sections on the piston. This results in four effective valve regions as the fluid flows past the piston. The coils contain a total of about 1.5 km magnetic wire. The completed damper is approximately 1 m long and with a mass of 250 kg. The damper contains approximately 5 liters of MR fluid. The amount of fluid energized by the magnetic field at any given instant is approximately 90 cm^3 . A summary of the parameters for the 20-ton damper are given in Table 4.

Figure 16 shows the experimental setup at the University of Notre Dame for the 20-ton MR fluid damper. The damper was attached to a 7.5 cm thick plate that was grouted to a 2 m thick strong floor. The damper is driven by a 560 kN actuator configured with a 305 lpm servo-valve with a bandwidth of 80 Hz. A Schenck-Pegasus 5910 servo-hydraulic controller is employed in conjunction with a 200 MPa, 340 lpm hydraulic pump.

Figure 17 shows the measured performance for the damper at 5 cm/sec (triangular displacement). The maximum force measured at full magnetic field strength is 201 kN at a piston velocity of 5 cm/sec, which is within 0.5% of the analytically predicted result [149]. Moreover, the dynamic range of the damper is well over the design specification of 10.

Because of their mechanical simplicity, low power requirements and high force capacity, magnetorheological (MR) dampers constitute a class of semi-active control devices that meshes well with the demands and constraints of civil infrastructure applications and will likely see increasing interest from the engi-

Table 4: Design Parameters for 20-Ton Seismic Damper.

Stroke	± 8 cm
F_{\max} / F_{\min}	10.1 @ 10 cm/s
Cylinder Bore (ID)	20.32 cm
Max. Input Power	< 50 watts
Max. Force (nominal)	200,000 N
Effective Axial Pole Length	8.4 cm
Coils	3×1050 turns
Fluid $\eta_p / \tau_{y(\text{field})}^2$	2×10^{-10} s/Pa
Fluid η_p	1 Pa-s
Fluid $\tau_{y(\text{field})}$ max	70 kPa
Gap	2 mm
Active Fluid Volume	~ 90 cm ³
Wire	16 gauge
Inductance (L)	6.6 henries
Coil Resistance (R)	3×7.3 ohms

Full-scale buildings are being controlled successfully; and attention is turning toward the features of a whole new family of actuators, especially those of semi-active type. Controllable fluid dampers provide a fascinating class of instances, with the magnetorheological fluids offering attractive properties.

It turns out that models for such devices lead one into issues of hybrid control and hysteresis, both of which are topics of considerable current interest in the controls community.

In summary, the modern thrust toward control of civil structures is providing a new opportunity for control engineers to make their work more understandable to the public, while at the same time making a genuine technical, economic, and social contribution.

And, there are hundreds of interesting ideas to ponder....!

References

- [1] T.T. Soong, *Active Structural Control: Theory and Practice*, Longman Scientific and Technical, Essex, England, 1990.
- [2] Y. Fujino, T.T. Soong and B.F. Spencer, Jr., "Structural Control: Basic Concepts and Applications," *Proc. ASCE Structures Congress XIV*, Chicago, Illinois, pp. 1277–1287, April, 1996.
- [3] G.W. Housner, et al., "Structural Control: Past Present and Future," *J. Engrg. Mech., ASCE*, September, 1997.
- [4] Yao, J.T.P., "Concept of Structural Control," *ASCE J. Struct. Div.*, vol. 98, pp. 1567–1574, 1972.
- [5] J. Suhardjo, B.F. Spencer, Jr. and A. Kareem, "Frequency Domain Optimal Control of Wind Excited Buildings," *J. Engrg. Mech., ASCE*, vol. 118, no. 12, pp. 2463–2481, 1992.
- [6] B.F. Spencer, Jr., J. Suhardjo and M.K. Sain, "Frequency Domain Optimal Control Strategies for Aseismic Protection," *J. Engrg. Mech., ASCE*, vol. 120, no. 1, pp. 135–159, 1994.
- [7] F. Jabbari, W.E. Schmitendorf and J.N. Yang, " H_{∞} Control for Seismic-Excited Buildings with Acceleration Feedback," *J. Engrg. Mech., ASCE*, vol. 21, no. 9, pp. 994–1002, 1995.
- [8] I.E. Kose, W.E. Schmitendorf, F. Jabbari and J.N. Yang, " H_{∞} Active Seismic Response Control Using Static Output Feedback," *J. Engrg. Mech., ASCE*, vol. 122, no. 7, pp. 651–659, 1996.
- [9] K. Nonami, H. Nishimura and H. Tian, " H_{∞} / μ Control-Based Frequency-Shaped Sliding Mode Control for Flexible Structures," *Proc. 1st World Conf. on Struct. Control*, Los Angeles, California, pp. TP4:110–119, August, 1994.
- [10] J.N. Yang, J.C. Wu and A.K. Agrawal, "Sliding Mode Control for Seismically Excited Linear Structures," *J. Engrg. Mech., ASCE*, vol. 121, no. 12, pp. 1386–1390, 1995.
- [11] R. Adhikari and H. Yamaguchi, "Sliding Mode Control of Gust Response of Tall Buildings," *Proc. 2nd Int. Workshop on Struct. Control*, Hong Kong, pp. 11–19, December, 1996.
- [12] M.P. Singh, E. Matheu and C. Beattie, "Output-Feedback Sliding Mode Control for Civil Engineering Structures," *Proc. 2nd Int. Workshop on Struct. Control*, Hong Kong, pp. 609–620, December, 1996.
- [13] J. Geoffrey Chase and H. Allison Smith, "Robust H_{∞} Control Considering Actuator Saturation – I: Theory; – II: Applications," *J. Engrg. Mech., ASCE*, vol. 122, no. 10, pp. 976–993, 1996.
- [14] A.K. Agrawal, J.N. Yang, W.E. Schmitendorf and F. Jabbari, "Stability of Actively Controlled Structures with Actuator Saturation," *J. Struct. Engrg., ASCE*, vol. 123, no. 4, pp. 505–512, 1997.
- [15] B.F. Spencer, Jr., M.K. Sain, J.C. Kantor and C. Montemagno, "Probabilistic Stability Measures for Controlled Structures Subject to Real Parameter Uncertainties," *Smart Mat. and Struct.*, vol. 1, pp. 294–305, 1992.
- [16] B.F. Spencer, Jr., M.K. Sain, C.-H. Won, D.C. Kaspari, Jr. and P.M. Sain, "Reliability-Based Measures Of Structural Control Robustness," *Struct. Safety*, vol. 15, pp. 111–129, 1994.
- [17] R.V. Field, Jr., L.A. Bergman and W.B. Hall, "Computation of Probabilistic Stability Measures for a Controlled Distributed Parameter System," *Prob. Engrg. Mech.*, vol. 10, no. 3, pp. 181–189, 1995.
- [18] R.V. Field, Jr., P.G. Voulgaris and L.A. Bergman, "Methods to Compute Probabilistic Measures of Robustness for Structural Systems," *J. Vib. and Control*, vol. 2, no. 4, pp. 447–464, 1996.
- [19] R.V. Field, Jr., P.G. Voulgaris and L.A. Bergman, "Probabilistic Stability Robustness of Structural Systems," *J. Engrg. Mech., ASCE*, vol. 122, no. 10, pp. 1012–1021, 1996.
- [20] R.V. Field, Jr., P.G. Voulgaris and L.A. Bergman, "Probability-Based Stability Assessment of Controlled Structures," *Proc. IFAC, 1996 Triennial World Congress*, San Francisco, California, vol. L, pp. 187-192, June 30-July 5, 1996.
- [21] R.V. Field, Jr. and L.A. Bergman, "Reliability-Based Covariance Control Design," *Proc. 1997 American Control Conf.*, Albuquerque, New Mexico, pp. WA01:11-15, June, 1997.
- [22] S. Nagarajaiah, "Fuzzy Controller for Structures with Hybrid Isolation System," *Proc. 1st World Conf. on Struct. Control*, Los Angeles, California, pp. TA2:67–76, August, 1994.

- [23] R.S. Subramaniam, A.M. Reinhorn, M.A. Riley and S. Nagarajah, "Hybrid Control of Structures Using Fuzzy Logic," *Microcomputers in Civil Engrg.*, vol. 11, no. 1, pp. 1–17, 1996.
- [24] L. Faravelli and T. Yao, "Use of Adaptive Network in Fuzzy Control of Civil Structures," *Microcomputers in Civil Engrg.*, vol. 11, pp. 67–76, 1996.
- [25] F. Casciati, L. Faravelli and T. Yao, "Control of Nonlinear Structures Using the Fuzzy Control Approach," *Nonlinear Dynamics*, vol. 11, pp. 171–187, 1996.
- [26] F. Casciati, "Checking the Stability of a Fuzzy Controller for Nonlinear Structures," *Microcomputers in Civil Engrg.*, vol. 12, pp. 205–215, 1997.
- [27] P. Venini and Y.K. Wen, "Hybrid Vibration Control of MDOF Hysteretic Structures with Neural Networks," *Proc. 1st World Conf. on Struct. Control*, Los Angeles, California, pp. TA3:53–62, August, 1994.
- [28] J. Ghaboussi and A. Joghataie, "Active Control of Structures Using Neural Networks," *J. Engrg. Mech., ASCE*, vol. 121, no. 4, pp. 555–567, 1995.
- [29] S.J. Dyke, B.F. Spencer, Jr., P. Quast and M.K. Sain, "The Role of Control-Structure Interaction in Protective System Design," *J. Engrg. Mech., ASCE*, vol. 121, no. 2, pp. 322–338, 1995.
- [30] R.E. Skelton and J. Lu, "Weighted Closed-Loop Identification and Control of Civil Structures," *Proc. SPIE Smart Mat. and Structures Conf.*, vol. 2721, pp. 106–117, 1996.
- [31] A. Nishitani, N. Yamada, Y. Nitta and S. Yamada, "Concept of Model Reduction for Structural Control," *Proc. 2nd Int. Workshop on Struct. Control*, Hong Kong, pp. 372–381, December, 1996.
- [32] H.A. Smith and A.G. Schemmann, "Modeling Issues Associated with Vibration Control of Cable-Stayed Bridges subjected to Multiple Support Excitation," *Proc. 2nd Int. Workshop on Struct. Control*, Hong Kong, pp. 509–520, December, 1996.
- [33] D.P. Tomasula, B.F. Spencer, Jr. and M.K. Sain, "Nonlinear Structural Control for Limiting Extreme Dynamic Responses," *J. Engrg. Mech., ASCE*, vol. 122, no. 3, pp. 218–229, 1996.
- [34] B.F. Spencer, Jr., T.L. Timlin, M.K. Sain and S.J. Dyke, "Series Solution of a Class of Nonlinear Optimal Regulators," *J. Opt. Theory and Appl.*, vol. 91, no. 5, pp. 321–345, 1996.
- [35] A.K. Agrawal and J.N. Yang, "Optimal Polynomial Control of Seismic-Excited Linear Structures," *J. Engrg. Mech., ASCE*, vol. 122, no. 8, pp. 753–761, 1996.
- [36] J.N. Yang, A.K. Agrawal and S. Chen, "Optimal Polynomial Control for Seismically Excited Non-linear and Hysteretic Structures," *Earthquake Engrg. and Struct. Dyn.*, vol. 25, no. 11, pp. 1211–1230, 1996.
- [37] A.K. Agrawal and J.N. Yang, "Static Output Polynomial Control for Linear Structures," *J. Engrg. Mech., ASCE*, vol. 123, no. 6, pp. 639–643, 1997.
- [38] L.L. Chung, R.C. Lin, T.T. Soong and A.M. Reinhorn, "Experiments on Active Control for MDOF Seismic Structures," *J. Engrg. Mech., ASCE*, vol. 115, no. 8, pp. 1609–1627, 1989.
- [39] A.M. Reinhorn, T.T. Soong, M.A. Riley, R.C. Lin, S. Aizawa and M. Higashino, "Full-Scale Implementation of Active Control. II: Instillation and Performance," *J. Struct. Engrg., ASCE*, vol. 119, no. 6, pp. 1935–1960, 1993.
- [40] P. Quast, M.K. Sain, B.F. Spencer, Jr. and S.J. Dyke, "Microcomputer Implementations of Digital Control Strategies for Structural Response Reduction," *Microcomputers in Civil Engrg.*, vol. 10, pp. 13–25, 1995.
- [41] S.J. Dyke, B.F. Spencer, Jr., P. Quast, D.C. Kaspari, Jr. and M.K. Sain, "Implementation of an Active Mass Driver Using Acceleration Feedback Control," *Microcomputers in Civil Engrg.*, vol. 11, pp. 305–323, 1996.
- [42] S.J. Dyke, B.F. Spencer, Jr., P. Quast, M. K. Sain, D.C. Kaspari, Jr. and T.T. Soong, "Acceleration Feedback Control of MDOF Structures," *J. Engrg. Mech., ASCE*, vol. 122, no. 9, pp. 907–918, 1996.
- [43] J.N. Yang, J.C. Wu, A.M. Reinhorn, M. Riley, W.E. Schmitendorf and F. Jabbari, "Experimental Verifications of H_{∞} and Sliding Mode Control for Seismically Excited Buildings," *J. Struct. Engrg., ASCE*, vol. 122, no. 1, pp. 69–75, 1996.
- [44] B.F. Spencer, Jr., S.J. Dyke, and H.S. Deoskar, "A Benchmark Problem in Structural Control," *Proc. ASCE Struct. Cong. XV*, Portland, Oregon, vol. 2, pp. 1265–1269, 1997.
- [45] B.F. Spencer, Jr., S.J. Dyke, and H.S. Deoskar, "Benchmark Problems in Structural Control – Part I: Active Mass Driver System; Part II: Active Tendon System," *Earthquake Engineering and Structural Dynamics*, to appear.
- [46] T. Kobori, "Future Direction on Research and Development of Seismic-Response-Controlled Structure," *Proc. 1st World Conf. on Struct. Control*, Los Angeles, California, Panel:19–31, August, 1994.
- [47] M. Sakamoto, T. Kobori, T. Yamada and M. Takahashi, "Practical Applications of Active and Hybrid Response Control Systems and Their Verifications by Earthquake and strong Wind Observations," *Proc. 1st World Conf. on Struct. Control*, Los Angeles, California, pp. WP2:90–99, August, 1994.
- [48] T.T. Soong and A.M. Reinhorn, "An Overview of Active and Hybrid Structural Control Research in the U.S.," *The Struct. Dyn. Design of Tall Buildings*, vol. 2, pp. 192–209, 1993.
- [49] K. Tanida, Y. Koike, K. Mutaguchi and N. Uno, "Development of Hybrid Active-Passive Damper," *Active and Passive Damping*, ASME, PVP–vol. 211, pp. 21–26, 1991.
- [50] K. Tanida, "Active Control of Bridge Towers During Erection," *Proc. 3rd Colloquium on Vib. Control of Struct., JSCE, part A*, pp. 173–184, 1995 (in Japanese).
- [51] Y. Koike, T. Murata, K. Tanida, T. Kobori, K. Ishii and Y. Takenaka, "Development of V-Shaped Hybrid Mass Damper and Its Application to High-Rise Buildings," *Proc. 1st World Conf. on Struct. Control*, Los Angeles, California, pp. FA2:3–12, August, 1994.
- [52] S. Yamazaki, N. Nagata and H. Abiru, "Tuned Active Dampers Installed in the Minato Mirai (MM) 21 Landmark Tower in Yokohama," *J. Wind Engrg. and Indust. Aerodyn.*, vol. 43, pp. 1937–1948, 1992.
- [53] S. Ohru, T. Kobori, M. Sakamoto, N. Koshika, I. Nishimura, K. Sasaki, A. Kondo and I. Fukushima, "Development of Active-Passive Composite Tuned Mass Damper and an Application to the High Rise Building," *Proc. 1st World Conf. on Struct. Control*, Los Angeles, California, pp. TP1:100–109, August, 1994.

- [54] H. Iemura and K. Izuno, "Development of the Self-Oscillating TMD and Shaking Table Tests," *Proc. 1st World Conf. on Struct. Control*, Los Angeles, California, pp. WP2:42–51, August, 1994.
- [55] S. Otsuka, I. Shimoda, N. Kawai, K. Inaba, M. Kurimoto, K. Yasui and M. Mochimaru, "Development and Verification of Active/Passive Mass Damper," *Proc. 1st World Conf. on Struct. Control*, Los Angeles, California, pp. WP2:72–79, August, 1994.
- [56] W. Cheng, W. Qu and A. Li, "Hybrid Vibration Control of Nanjing TV Tower under Wind Excitation," *Proc. 1st World Conf. on Struct. Control*, Los Angeles, California, pp. WP2:32–41, August, 1994.
- [57] M. Higashino and S. Aizawa, "The Application of Active Mass Damper System in Actual Buildings," *Proc. Int. Workshop on Struct. Control*, Honolulu, Hawaii, pp. 194–205, 1993.
- [58] J. Hirai, A. Hisanori and E. Tsuji, "Study on Tuned Active Damper for Control Tower of Kansai International Airport," *Proc. Int. Workshop on Struct. Control*, Honolulu, Hawaii, pp. 206–13, 1993.
- [59] H. Ohyama, K. Tanaka, N. Arai, Y. Ishiguro, M. Ishii, K. Murakoshi, Y. Nakamura, H. Miyano, H. Hora and T. Fujita, "Practical Application of Hybrid Mass Damper Using AC-Servomotor for Vibration Control of a Slender Tall Building," *Proc. 1st World Conf. on Struct. Control*, Los Angeles, California, pp. WP2:62–71, August, 1994.
- [60] T. Suzuki, M. Kageyama, A. Nobata, S. Inaba and O. Yoshida, "Active Vibration Control System Installed in a High-rise building," *Proc. 1st World Conf. on Struct. Control*, Los Angeles, California, pp. FP3:3–11, August, 1994.
- [61] Y. Fujino, "Recent Research and Developments on Control of Bridges under Wind and Traffic Excitations in Japan," *Proc. Int. Workshop on Struct. Control*, pp. 144–150, 1994.
- [62] Y. Fujino and H. Yamaguchi, "Implemented Examples of Structural Response Control for Civil Structures with Emphasis on Active Control," *Japan Soc. Steel Const.*, vol. 12, pp. 16–22, 1994.
- [63] T. Fujita, T. Kamada, N. Masaki and Y. Suizu, "Development of Hybrid Mass Damper with Convertible Active and Passive Modes Using Hydraulic Actuator and Multistage Rubber Bearing," *Proc. 1st World Conf. on Struct. Control*, Los Angeles, California, pp. FA4:43–52, August, 1994.
- [64] T. Fujita, T. Kamada, T. Teramoto, H. Kitamura, Y. Suizu, N. Masaki, T. Kanno and H. Kawachi, "Application of Hybrid Mass Damper Using Hydraulic Actuator and Multistage Rubber Bearing to High-Rise Building," *Proc. 1st World Conf. on Struct. Control*, Los Angeles, California, pp. FA4:53–62, August, 1994.
- [65] Y. Nakamura, K. Tanaka, M. Ishii, M. Hirasawa, M. Nakayama, H. Ohyama and T. Fujita, "Fault Diagnosis Method Using Energy Absorbing Performance for Hybrid Mass Damper for Vibration Control of Tall Buildings," *Proc. 1st World Conf. on Struct. Control*, Los Angeles, California, pp. FA2:33–42, August, 1994.
- [66] K. Shiba, K. Tamura, Y. Inada and N. Yamaura, "Vibration Control Characteristics of a Hybrid Mass Dampers System Through Earthquake Observation Records of a Tall Building," *Proc. 1st World Conf. on Struct. Control*, Los Angeles, California, pp. WP2:80–89, August, 1994.
- [67] M. Yamamoto and S. Aizawa, "Control Effects of Active Mass Damper System Installed on Actual Buildings," *Proc. 1st World Conf. on Struct. Control*, Los Angeles, California, pp. FP1:13–22, August, 1994.
- [68] M. Sakamoto and T. Kobori, "Applications of Structural Response Control (Reviews from the Past and Issues Toward the Future)," *Proc. 2nd Int. Workshop on Struct. Control*, Hong Kong, pp. 470–481, December, 1996.
- [69] H. Iemura, A. Igarashi, Y. Inoue and M. Sakamoto, "Nonlinear Active Control Experiment of a Real Size Frame Structure," *Proc. 2nd Int. Workshop on Struct. Control*, Hong Kong, pp. 241–252, December, 1996.
- [70] K. Seto, "Vibration Control Method for Flexible Structures Arranged in Parallel," *Proc. 1st World Conf. on Struct. Control*, Los Angeles, California, vol. 3, pp. FP3:62–71, August, 1994.
- [71] H. Cao, A.M. Reinhorn and T.T. Soong, "Design of an Active Mass Damper for a Tall TV Tower in Nanjing, China," *Engrg. Struct.*, vol. 19, 1997.
- [72] M.A. Riley, H. Cao, A.M. Reinhorn and T.T. Soong, "Design of an Active Mass Damper for a 340m Transmission and Observation Tower," *Proc. 8th World Conf. on Wind Engineering*, Baltimore, Maryland, June, 1997.
- [73] J.C. Wu and J.N. Yang, "Continuous Sliding Mode Control of a TV Transmission Tower Under Stochastic Wind," *Proc. American Control Conf.*, vol. 2, pp. 883–887, Albuquerque, New Mexico, June, 1997.
- [74] K. Seto and Y. Matsumoto, "A Structural Vibration Control Method of Flexible Buildings in Response to Large Earthquakes and Strong Wind," *Proc. 2nd Int. Workshop on Struct. Control*, Hong Kong, pp. 490–496, December, 1996.
- [75] A. Mita and M.Q. Feng, "Response Control Strategy for Tall Buildings Using Interaction between Mega and Sub-Structures," *Proc. Int. Workshop on Civil Infrastructural Systems*, Taipei, Taiwan, Republic of China, pp. 329–341, 1994.
- [76] A. Mita and M. Kaneko, "Vibration Control of Tall Buildings Utilizing Energy Transfer into Sub-Structural Systems," *Proc. 1st World Conf. on Struct. Control*, Los Angeles, CA, pp. TA2:31–40, August, 1994.
- [77] W. Chai and M.Q. Feng, "Seismic Performance of Hybrid Controlled Mega-Sub Buildings," *Proc. 11th World Conf. on Earthquake Engrg.*, Acapulco, Mexico, June, 1996.
- [78] J.I. Craig, A.J. Carlisle, B.J. Goodno, C.C. Hsu and G.D. Sweriduk, "Active-passive Damping for Structural Response Attenuation in Buildings with Cladding," *Proc. ATC 17-1 Seminar on Seismic Isolation, Passive Energy Dissipation, and Active Control*, San Francisco, vol. 2, pp. 775–786, 1993.
- [79] J.-P. Pinelli, J.I. Craig and B.J. Goodno, "Energy-Based Seismic Design of Ductile Cladding Systems," *J. Struct. Engrg., ASCE*, vol. 121, no. 3, pp. 567–578, 1995.
- [80] P.B. Shing, M. Dixon, N. Kermiche, R. Su and D.M. Frangopol, "Hybrid Control Techniques for Building Structures," *Proc. 1st World Conf. on Struct. Control*, Los Angeles, California, pp. WP2:100–109, August, 1994.
- [81] M. Kawatani, Y. Yamada, M. Shimono and A. Mori, "Hybrid Control of Traffic-Induced Vibration of Girder Bridges," *Proc. 1st World*

- Conf. on Struct. Control*, Los Angeles, California, pp. TA2:3–10, August, 1994.
- [82] L. Petti, T.T. Soong and B. Palazzo, “Hybrid Mass Dampers for Structural Control against Wind and Earthquakes,” *Proc. 1st World Conf. on Struct. Control*, Los Angeles, California, pp. TP1:110–118, August, 1994.
- [83] K. Tamura, K. Shiba, Y. Inada and A. Wada, “Control Gain Scheduling of a Hybrid Mass Damper System Against Wind Response of Tall Buildings,” *Proc. 1st World Conf. on Struct. Control*, Los Angeles, California, pp. FA2:13–22, August, 1994.
- [84] T. Niiya, S. Ishimaru, T. Koizumi and S. Takai, “A Hybrid System Controlling Large Amplitude Vibrations of High-Rise Buildings,” *Proc. 1st World Conf. on Struct. Control*, Los Angeles, California, pp. FA2:43–52, August, 1994.
- [85] J.M. Kelly, “Aseismic Base Isolation: Its History and Prospects,” *Proc. 1st World Congress on Joints and Bearings*, ACI-SP-70, vol. 1, pp. 549–586, 1981.
- [86] J.M. Kelly, “Aseismic Base Isolation: Review and Bibliography,” *Soil Dynamics and Earthquake Engrg.*, vol. 5, no. 3, pp. 202–216, 1986.
- [87] I.G. Buckle and R.L. Mayes, “Seismic Isolation History, Application and Performance--A World View,” *Earthquake Spectra*, vol. 6, no. 2, pp. 161–201, 1990.
- [88] T.T. Soong and M.C. Constantinou (eds.), *Passive and Active Structural Vibration Control in Civil Engrg.*, Springer-Verlag, Wien and New York, 1994.
- [89] A.M. Reinhorn, T.T. Soong, and C.Y. Wen, “Base-Isolated Structures with Active Control,” *Proc. ASME PVP Conf.*, San Diego, California, PVP-127, pp. 413–420, 1987.
- [90] J.M. Kelly, G. Leitmann and A.G. Soldatos, “Robust Control of Base-Isolated Structures under Earthquake Excitation,” *J. Optimization Theory and Applications*, vol. 53, no. 2, pp. 159–180, 1987.
- [91] K. Yoshida, S. Kang and T. Kim, “LQG Control and H_∞ Control of Vibration Isolation for Multi-Degree-of-Freedom Systems,” *Proc. 1st World Conf. on Struct. Control*, Los Angeles, California, pp. TP4:43–52, August, 1994.
- [92] W.E. Schmitendorf, F. Jabbari and J.N. Yang, “Robust Control Techniques for Buildings Under Earthquake Excitation,” *Earthquake Engrg. and Struct. Dyn.*, 23, pp. 539–552, 1994.
- [93] J.N. Yang, J.C. Wu, A.M. Reinhorn and M. Riley, “Control of Sliding-Isolated Buildings Using Sliding-Mode Control,” *J. Struct. Engrg.*, ASCE, vol. 122, no. 2, pp. 179–186, 1996.
- [94] A.M. Reinhorn and M.A. Riley, “Control of Bridge Vibrations with Hybrid Devices,” *Proc. 1st World Conf. on Struct. Control*, Los Angeles, California, pp. TA2:50–59, August, 1994.
- [95] M.Q. Feng, M. Shinozuka and S. Fujii, “Friction-Controllable Sliding Isolation System,” *J. Engrg. Mech.*, ASCE, vol. 119 (9), pp. 1845–1864, 1993.
- [96] J.N. Yang, J.C. Wu, K. Kawashima and S. Unjoh, “Hybrid Control of Seismic-Excited Bridge Structures,” *Earthquake Engrg. and Struct. Dyn.*, vol. 24, no. 11, pp. 1437–1451, 1995.
- [97] N. Luo, J. Rodellar and M. De La Sen, “Robust Active Control of Base Isolated Structures Including Actuator Dynamics,” *Proc. 2nd Int. Workshop on Struct. Control*, Hong Kong, pp. 299–310, December, 1996.
- [98] J.A. Inaudi, J.M. Kelly and J.P. Pu, “Optimal Control and Frequency Shaping Techniques for Active Isolation,” *Proc. of ATC Seminar of Seismic Isolation, Passive Energy Dissipation, and Active Control*, San Francisco, vol. 2, pp. 787–798, 1993.
- [99] S.J. Dyke, B.F. Spencer, Jr., M.K. Sain and J.D. Carlson, “Seismic Response Reduction using Magnetorheological Dampers,” *Proc. IFAC World Congress*, San Francisco, CA, June 30 - July 5, 1996.
- [100] S.J. Dyke, B.F. Spencer, Jr., M.K. Sain and J.D. Carlson, “Modeling and Control of Magnetorheological Dampers for Seismic Response Reduction,” *Smart Mat. and Struct.*, vol. 5, pp. 565–575, 1996.
- [101] S.J. Dyke, B.F. Spencer, Jr., M.K. Sain and J.D. Carlson, “Experimental Verification of Semi-active Structural Control Strategies Using Acceleration Feedback,” *Proc. 3rd Int. Conf. on Motion and Vib. Control*, Chiba, Japan, vol. III, pp. 291–296, 1996.
- [102] Q. Feng and M. Shinozuka, “Use of a Variable Damper for Hybrid Control of Bridge Response under Earthquake,” *Proc. U.S. National Workshop on Struct. Control Research*. USC Publication no. CE-9013, 1990.
- [103] K. Kawashima and S. Unjoh, “Variable Dampers and Variable Stiffness for Seismic Control of Bridges,” *Proc. Int. Workshop on Struct. Control*, Honolulu, Hawaii, pp. 283–297, 1993.
- [104] K. Kawashima, S. Unjoh and K. Shimizu, “Experiments on Dynamics Characteristics of Variable Damper,” *Proc. Japan Nat. Symp. on Struct. Resp. Control*, Tokyo, Japan, p.121, 1992.
- [105] M.D. Symans, M.C. Constantinou, D.P. Taylor and K.D. Garjost, “Semi-Active Fluid Viscous Dampers for Seismic Response Control,” *Proc. 1st World Conf. on Struct. Control*, Los Angeles, California, pp. FA4:3–12, August, 1994.
- [106] M.D. Symans and M.C. Constantinou, “Experimental Study of Seismic Response of Structures with Semi-Active Damping Control Systems,” *Proc. Structures Congress XIV*, Chicago, IL, April 15-18, 1996.
- [107] R.L. Sack and W. Patten, “Semiactive Hydraulic Structural Control,” *Proc. Int. Workshop on Struct. Control*, USC Publication Number CE-9311, pp. 417-431, 1994.
- [108] W.N. Patten, Q. He, C.C. Kuo, L. Liu and R.L. Sack, “Suppression of Vehicle-Induced Bridge Vibration via a Semiactive Structural Controller,” *Proc. 1st World Conf. on Struct. Control*, Los Angeles, California, pp. FA1:30–38, August, 1994.
- [109] D. Hrovat, P. Barak and M. Rabins, “Semi-Active Versus Passive or Active Tuned Mass Dampers for Structural Control,” *J. Engrg. Mech.*, vol. 109, no. 3, pp. 691–705, 1983.
- [110] T. Mizuno, T. Kobori, J. Hirai, Y. Matsunaga and N. Niwa, “Development of Adjustable Hydraulic Dampers for Seismic Response Control of Large Structure,” *ASME PVP Conf.*, vol. 229, pp. 163–170, 1992.
- [111] R.L. Sack, C.C. Kuo, H.C. Wu, L. Liu and W.N. Patten, “Seismic Motion Control via Semiactive Hydraulic Actuators,” *Proc. U.S. Fifth National Conf. on Earthquake Engrg.*, Chicago, Illinois, 1994.
- [112] W.N. Patten, C.C. Kuo, Q. He, L. Liu and R.L. Sack, “Seismic Structural Control Via Hydraulic Semiactive Vibration Dampers

- (SAVD)," *Proc. 1st World Conf. on Struct. Control*, Los Angeles, California, pp. FA2:83–92, August, 1994.
- [113] N. Kurata, T. Kobori, M. Takahashi, N. Niwa and H. Kurino, "Shaking Table Experiment of Active Variable Damping System," *Proc. 1st World Conf. on Struct. Control*, Los Angeles, California, pp. TP2:108–117, August, 1994.
- [114] Z. Liang, M. Tong and G.C. Lee, "Real-Time Structural Parameter Modification (RSPM): Development of Innervated Structures," *Technical Report NCEER-95-0012*, National Center for Earthquake Engineering Research, Buffalo, New York, 1995.
- [115] J.N. Yang, J.C. Wu and Z. Li, "Control of Seismic-Excited Buildings using Active Variable Stiffness Systems," *Engrg. Struct.*, vol. 18, no. 8, pp. 589–596, 1996.
- [116] W.D. Iwan and L.J. Wang, "New Developments in Active Interaction Control," *Proc. 2nd Int. Workshop on Struct. Control*, Hong Kong, pp. 253–262, December, 1996.
- [117] J.A. Inaudi, J.C. Hayen and W.D. Iwan, "A Semi-Active Damping Brace System," *J. Engrg. Mech., ASCE*, submitted 1997.
- [118] T. Kobori, M. Takahashi, T. Nasu, N. Niwa and K. Ogasawara, "Seismic Response Controlled Structure with Active Variable Stiffness System," *Earthquake Engrg. and Struct. Dyn.*, vol. 22, pp. 925–941, 1993.
- [119] S. Kamagata and T. Kobori, "Autonomous Adaptive Control of Active Variable Stiffness System for Seismic Ground Motion," *Proc. 1st World Conf. on Struct. Control*, Los Angeles, California, pp. TA4:33–42, August, 1994.
- [120] Z. Akbay and H.M. Aktan, "Intelligent Energy Dissipation Devices," *Proc. Fourth U.S. National Conf. on Earthquake Engrg.*, vol. 3, no. 4, pp. 427–435, 1990.
- [121] Z. Akbay and H.M. Aktan, "Actively Regulated Friction Slip Devices," *Proc. 6th Canadian Conf. on Earthquake Engrg.*, pp. 367–374, 1991.
- [122] S. Kannan, H.M. Uras and H.M. Aktan, "Active Control of Building Seismic Response by Energy Dissipation," *Earthquake Engrg. and Struct. Dyn.*, vol. 24, no. 5, pp. 747–759, 1995.
- [123] S. Cherry, "Research on Friction Damping at the University of British Columbia," *Proc. Int. Workshop on Struct. Control*, USC Publication Number CE-9311, pp. 84–91, 1994.
- [124] D.J. Dowdell, and S. Cherry, "Semi-active Friction Dampers for Seismic Response Control of Structures," *Proc. Fifth US National Conf. on Earthquake Engrg.*, vol. 1, pp. 819–828, 1994.
- [125] D.J. Dowdell and S. Cherry, "Structural Control Using Semi-Active Friction Dampers," *Proc. 1st World Conf. on Struct. Control*, Los Angeles, California, pp. FA1:59–68, August, 1994.
- [126] A. Kareem, "The Next Generation of Tuned Liquid Dampers," *Proc. 1st World Conf. on Struct. Control*, Los Angeles, California, pp. FP5:19–28, August, 1994.
- [127] J.Y.K. Lou, L.D. Lutes and J.J. Li, "Active Tuned Liquid Damper for Structural Control," *Proc. 1st World Conf. on Struct. Control*, Los Angeles, California, pp. TP1:70–79, August, 1994.
- [128] M.A. Haroun, J.A. Pires and A.Y.J. Won, "Active Orifice Control in Hybrid Liquid Dampers," *Proc. 1st World Conf. on Struct. Control*, Los Angeles, California, FA1:69–78, August, 1994.
- [129] M. Abe, S. Kimura and Y. Fujino, "Control Laws for Semi-Active Tuned Liquid Column Dampers with Variable Orifice Openings," *Proc. 2nd Int. Workshop on Struct. Control*, pp. 5–10, Hong Kong, December, 1996.
- [130] W.M. Winslow, "Method and Means for Translating Electrical Impulses Into Mechanical Force," US Patent no. 2,417,850, 1947.
- [131] J. Rabinow, "The Magnetic Fluid Clutch," *AIEE Transactions*, vol. 67, pp. 1308–1315, 1948.
- [132] W.M. Winslow, "Induced Fibration of Suspensions" *J. Applied Physics*, vol. 20, pp. 1137–1140, 1949.
- [133] R.C. Ehrgott and S.F. Masri, "Structural Control Applications of an Electrorheological Device," *Proc. Int. Workshop on Struct. Control*, USC Publication Number CE-9311, pp. 115–129, 1994.
- [134] H.P. Gavin, R.D. Hanson and F.E. Filisko, "Electrorheological Dampers, Part I: Analysis and Design," *J. Appl. Mech., ASME*, vol. 63, no. 3, pp. 669–675, 1996.
- [135] H.P. Gavin, R.D. Hanson and F.E. Filisko, "Electrorheological Dampers, Part II: Testing and Modeling," *J. Appl. Mech., ASME*, vol. 63, no. 3, pp. 676–682, 1996.
- [136] F. Gordaninejad and R. Bindu, "The Effect of Scale Factor on the Performance of ERF Dampers," *Proc. 5th Int. Conf. on ERF, MR Suspensions and Associated Tech.*, Sheffield, England, pp. 318–326, 1995.
- [137] S.A. Burton, N. Makris, I. Konstantopoulos and P.J. Antsaklis, "Modeling the Response of ER Damper: Phenomenology and Emulation," *J. Engrg. Mech., ASCE*, vol. 122, no. 9, pp.897–906, 1996.
- [138] N.H. McClamroch and H.P. Gavin, "Closed Loop Structural Control Using Electrorheological Dampers," *Proc. American Control Conf.*, Seattle, Washington, pp. 4173–4177, 1995.
- [139] J.D. Carlson "The Promise of Controllable Fluids," *Proc. of Actuator 94* (H. Borgmann and K. Lenz, Eds.), AXON Technologie Consult GmbH, pp. 266–270, 1994.
- [140] J.D. Carlson and K.D. Weiss, "A Growing Attraction to Magnetic Fluids," *Machine Design*, August, pp. 61–64, 1994.
- [141] J.D. Carlson, D.M. Catanzarite and K.A. St. Clair, "Commercial Magneto-Rheological Fluid Devices," *Proc. 5th Int. Conf. on ER Fluids, MR Fluids and Associated Technology*, U. Sheffield, UK, 1995.
- [142] M.J. Crosby, R.A. Harwood and D. Karnopp, "Vibration Control Using Semi-Active Force Generators," *Trans. of ASME*, no. 73-DET-122, 1973.
- [143] D. Karnopp and M.J. Crosby, "System for Controlling the Transmission of Energy Between spaced Members," U.S. Patent no. 3,807,678, 1974.
- [144] D.E. Ivers and L.R. Miller, "Semi-Active Suspension Technology: An Evolutionary View," Lord Corporation Publication #LL-6005, 1994.
- [145] K.D. Weiss, T.G. Duclos, J.D. Carlson, M.J. Chrzan and A.J. Margida, "High Strength Magneto- and Electrorheological Fluids," Society of Automotive Engineers, SAE Paper #932451, 1993.
- [146] Lord Corporation, "VersaFlo Product Information Sheet," Lord Corporation Publication #PI02-MRX-135CD, 1995.
- [147] B.F. Spencer, Jr., S.J. Dyke, M.K. Sain and J.D. Carlson, "Idealized Model of a Magnetorheological Damper," *Proc. 12th Conf. on*

Analysis and Computation, ASCE, Chicago, Illinois, April 15–18, pp. 361–370, 1996.

[148] B.F. Spencer, Jr., S.J. Dyke, M.K. Sain and J.D. Carlson, “Phenomenological Model of a Magnetorheological Damper,” *J. Engrg. Mech.*, ASCE, vol. 123, no. 3, pp. 230–238, 1997.

[149] B.F. Spencer, Jr., J.D. Carlson, M.K. Sain and G. Yang, “On the Current Status of Magnetorheological Dampers: Seismic Protection of Full-Scale Structures,” *Proc. American Control Conf.*, Albuquerque, New Mexico, pp. 458–462, 1997.

[150] J.D. Carlson and B.F. Spencer, Jr., “Magneto-Rheological Fluid Dampers for Semi-Active Seismic Control,” *Proc. 3rd Int. Conf. on Motion and Vib. Control*, Chiba, Japan, vol. III, pp. 35–40, 1996.

[151] A. Papalou and S.F. Masri, “An Experimental Study of Particle Dampers Under Random Excitation,” *Proc. 1st World Conf. on Struct. Control*, Los Angeles, CA, pp. FP2:18-24, August, 1994.

[152] T.K. Caughey and M.P. Karyeaclis, “Stability of Semi-Active Impact Damper, Part I–Global Behavior; Part II–Periodic Solutions,” *J. Appl. Mech.*, vol. 56, no. 4, pp. 926-940, 1989.

[153] S.F. Masri, R.K. Miller, T.J. Dehghanyar and T.K. Caughey, “Active Parameter Control of Nonlinear Vibrating Structures,” *J. Appl. Mech.*, vol. 56, pp. 658-666, Sept., 1989.

[154] S.F. Masri, S. Chavakula and T.K. Caughey, “Control of Intelligent Nonlinear Adaptive Structures Under Earthquake Excitation,” *J. Struct. Control*, vol. 1, no. 1-2, pp. 23-38, Dec., 1994.

[155] L. Sun and Y. Goto, “Application of Fuzzy Theory to Variable Dampers for Bridge Vibration Control,” *Proc. 1st World Conf. on Struct. Control*, Los Angeles, California, pp. WP1:31–40, August, 1994.

[156] J.A. Inaudi, “Modulated Homogeneous Friction: A Semi-active Damping Strategy,” *Earthquake Engrg. and Struct. Dyn.*, vol. 26, no. 3, pp. 361–376, 1997.

[157] T.K. Caughey, “Musings on Structural Control,” *Proc. Int. Workshop on Struct. Control*, Honolulu, Hawaii, pp. 65-75, 1993.

[158] T.J. Reid, “Free Vibrations and Hysteretic Damping,” *J. Aero. Soc.*, vol. 69, pp. 283, 1956.